

A large, rectangular, light-colored hot tub is the central focus, situated on a modern outdoor patio. The hot tub has a control panel on the right side and a glowing light strip at the bottom. In the background, there is a stone wall, a white sectional sofa, and a view of the ocean at sunset. The sky is filled with soft, colorful clouds. The Jacuzzi logo is in the top right corner.

Jacuzzi®

J5™ Collection

Owner's Manual

[Rev B](#)

J509™

J508L™

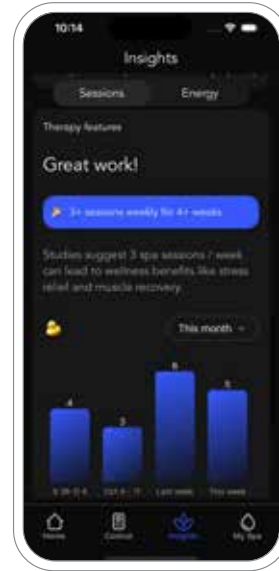
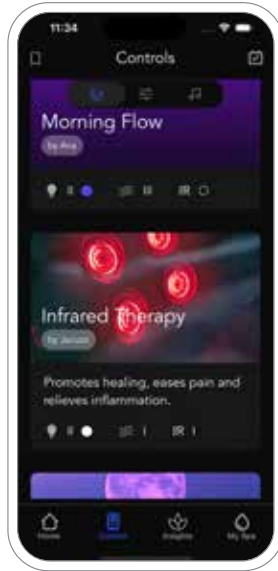
J508™

Table of Contents

Intro	1
Getting started	1
Preparation	1
Fill Your Spa	1
Turn On Power	2
Set Up the Interface	2
Adding Chemicals	3
Heating Your Spa	4
While you wait	4
Locating Your Serial Number	4
Install the Cover Sensor	4
Install the Cover Locks	5
Register Your Spa	5
Enjoying your spa	6
Get to Know Your Spa	8
Spa Overview	8
Interface Overview	9
Managing Profiles & Settings	11
Profiles	11
Settings	11
Spa Programming	12
General Menus	12
Spa Care	15
Heat Modes	15
Heat Modes (when Heat Pump is installed)	15
Water Care	15
Cleaning Boost Cycle	16
Cleanup Cycle	16
Reminders	16
Security	17
Troubleshooting	18
Spa Maintenance	19
Maintenance Schedule	19
Changing the Air Filter and Sensor Battery for the True Water® System	20
Air Filter	20
Pressure Sensor	20
Spa Water Care	21
Important Notes:	22
Manage Your Water Chemistry	23
Clean the Filters	23
Clean the Spa Cover	24
Draining the Spa	25
Refill the Spa	25
Pillow Care	25
Cleaning the Spa Exterior & Control Panel	25
Cleaning the Spa Interior	25
Winterizing	26
Restarting Your Spa in Cold Weather	26
Choosing A Location	26
Outdoor Location	27
Indoor Location	28
Message Codes	28
Troubleshooting Procedures	31

FOR ELECTRICIANS	32
General Electrical Safety Instructions.....	32
Equipment Area.....	32
Power Requirements.....	33
Electrical Wiring Instructions.....	34
Circuit Board Wiring Diagrams.....	36
Jacuzzi® Hot Tub FAQ.....	38
Water Care & True Water® System.....	38
Cleaning & Maintenance.....	38
SmartTub® System.....	39
Safety & Usage.....	39
Cover & Accessories.....	39
Detailed Spa Operations and Programming	40
Start-up.....	40
Initial Start-up Menus.....	40
Create a profile.....	41
Edit/Delete/Switch profiles.....	42
Home Menu	43
Heating	43
Extended Temperature Feature.....	44
Modes	44
Infrared therapy Mode.....	45
Sleep Well Mode.....	45
Rejuvenation Mode.....	45
Post Workout Mode.....	45
Celebration Mode.....	46
Saving a New Mode.....	46
Tuning.....	47
Tuning Quick Access.....	47
Sound.....	47
Information Buttons.....	48
Light Intensity Control.....	48
Lighting Options Menu.....	49
Hydromassage Control.....	49
Settings	50
General Menus.....	50
About Menu.....	51
SmartTub®.....	51
Wi-Fi.....	51
Sleep Timer.....	51
Date & Time.....	52
Language.....	52
Temperature.....	52
Exterior Light.....	53
Spa Care.....	53
Heat Modes.....	53
Heat Modes (when Heat Pump is installed).....	53
Water Care.....	54
Reminders.....	55
Reminder Message.....	56
Security.....	56
Troubleshooting.....	57

Every J5™ comes equipped with SmartTub® for a more enjoyable experience. Click this [Link](#) to access more information about the SmartTub® app.



Intro

Step into the future of relaxation with the all-new Jacuzzi® J5™. Crafted for those who expect the very best, the J5 delivers an immersive, multi-sensory experience unlike anything before. Its advanced features adapt seamlessly to you—personalized, intuitive, and effortless—so every soak feels like it was designed exclusively for your comfort and well-being.

It's time to make wellness yours. Welcome to the J5.

Getting started

Preparation

Refer to the section "Choosing a Location" to determine where to place your hot tub, page 26. Your dealer is a great source for helping you set up your hot tub. Now that your J5 has been installed, it's time to get familiar with the product and features. Before you begin, please ensure all installation steps and safety requirements have been completed by qualified electrical professional in your region. (Reference "FOR ELECTRICIANS" on page 32)

Setting up your hot tub starts with filling it, adding and balancing chemicals, and letting it heat up. Meanwhile, you can start getting familiar with its amazing features, page 8.

Things to do now:

- Fill and prepare water – page 1
- Add and balance start-up chemicals - page 3
- Download and set up SmartTub® App – page 3
- Install cover sensor and cover – page 5
- Register your hot tub to activate the warranty and get to know your spa – page 5

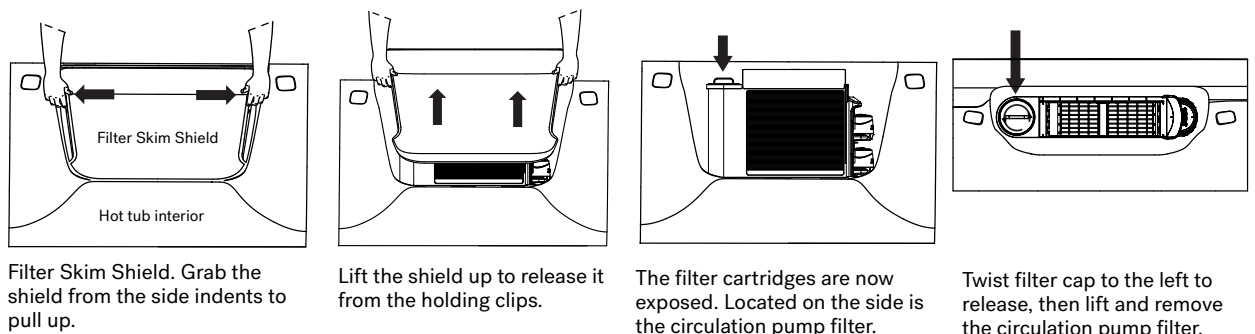
Fill Your Spa

If necessary, clear out debris and clean the spa before filling. Make sure all drains and drain plugs are closed before filling. Refer to page 8 for spa diagram to locate the skim shield.

Note: All filters are shipped with a plastic liner. Remove the liner from each filter prior to fill up.

- **Do not** fill your spa with water from a water softener, as this may be corrosive to metal components. If your water is extremely hard, you can fill halfway with hard water, and the rest with softened water.
- Place your garden hose into the Circulation Pump filter area (Figure A).
- Fill until water covers all jets but does not touch the bottom of the lowest pillow.
 - **TIP:** to avoid overfilling your spa, set a timer to remind yourself to monitor the water level as it fills. For example, set a 15-minute timer and repeat the timer until the spa is properly filled.
 - Maintaining proper water levels throughout the use of your spa assures efficient operation and efficient electrical usage.
- When you are done filling:
 - Reinsert the circulation pump filter and twist counterclockwise to lock.
 - Reinstall the filter skim shield.

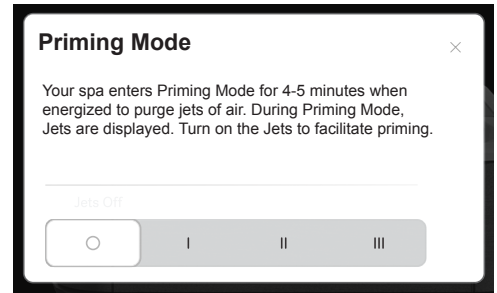
Figure A



Turn On Power

Once the water is filled just above the highest jet, the filter and filter skim shield are reinstalled, turn on power to the spa at your home's circuit breaker.

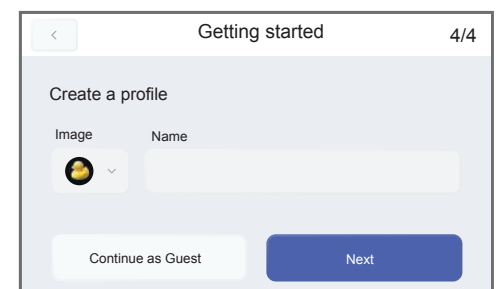
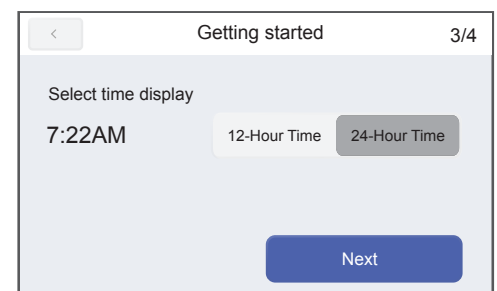
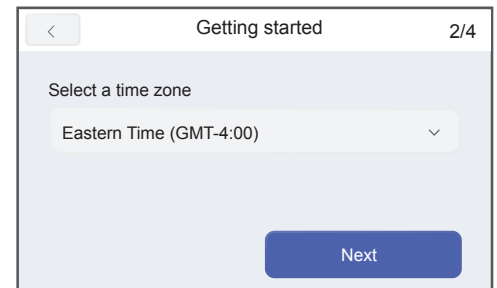
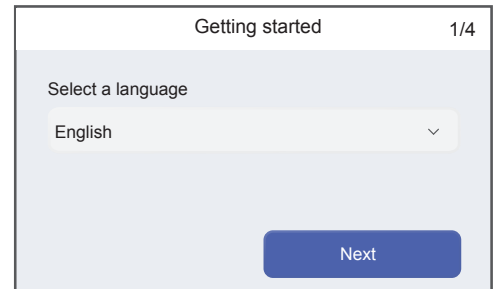
- Your topside Control Panel will activate and initialize the setup.
- The Priming Mode will display. You must manually activate the pumps by tapping each of the 3 hydromassage therapy settings as instructed on the display. The cycle lasts approximately 4-5 minutes.



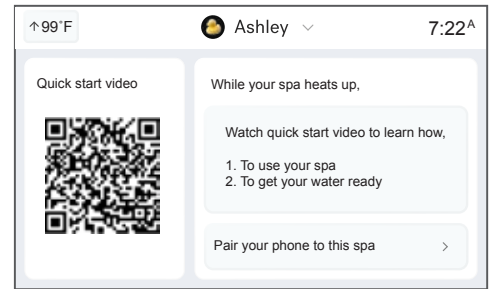
Set Up the Interface

At the very first activation, some of the settings need to be programmed. Follow the Getting Started steps on the screen to set up language, time zone, time display format, and create a profile. You can watch a quick start video (page 3) and pair to SmartTub.

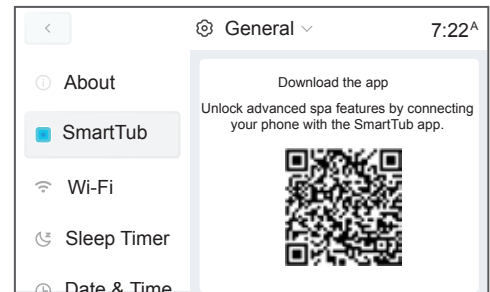
- Language
 - Default is English.
 - There are nine other languages you can select. Use the drop-down menu.
- Time Zone
 - Default is Pacific Standard Time
 - There are 25 other time zones you can select. Use the drop-down menu.
- Time Display
 - Default is 12-hour display.
 - There is also a 24-hour display. Use the drop-down menu.
- Create a Profile
 - Default is the Guest profile.
 - You can create and save a custom profile. Use the drop-down menu.
 - Choose an image.
 - Type in your name.



- Quick Start Video
 - Watch the Quick Start Video to learn more! Click on the QR code.



- Download the SmartTub® app
 - The SmartTub app lets you adjust your spa's temperature from anywhere and offers wellness and environmental insights based on your sessions and energy use. It also simplifies ownership by sending you helpful notifications.
 - At the end of the initial interface setup, tap Pair your phone to this spa on the Control Panel and scan the QR code with your phone.
 - To find this screen again, tap the Profile name at the top of the screen, then tap All Settings, and then on the left side tap SmartTub.
 - If you are not at your hot tub, search SmartTub in your personal device's app store.
 - Once downloaded, open the app and follow the Sign Up instructions.



Adding Chemicals

Before you start this step, make sure to have a few key chemicals on hand: a sanitizer (like chlorine or bromine), pH adjusters (increaser and decreaser), a total alkalinity increaser, and water testing strips. You may also need a calcium hardness increaser and a metal remover and/or phosphate remover, especially if using well water.

- Contact your authorized Jacuzzi dealer to purchase chemicals.
- Do not use pool products to ensure longevity of your spa's components.
- Do not add chlorine tablets or acid to your spa, as this might damage your spa, irritate your skin, and void the manufacturer warranty.
- Store chemicals in a safe and/or locked location, keep them away from children.
- Average gallons per model:

<u>Model</u>	<u>Average Gallons</u>
J509	505 Gallons (1,912 L)
J508L	420 Gallons (1,590 L)
J508	425 Gallons (1,609 L)

Follow these simplified steps to get your water set. Reference the Detailed Water Setup section (page 21) for step-by-step instructions about proper water maintenance.

- Test your water using the AquaCheck Test Strips (or similar product). Follow the manufacturer's instructions to accurately read the measurements.
- Your water chemistry should always fall within the following parameters. Remember, chlorine and bromine numbers are lower with the True Water system.
 - pH 7.2-7.8
 - Free chlorine 0.5 ppm (1 ppm outside the U.S.)
 - Free bromine 2 ppm
 - Total Alkalinity 80-120 ppm
 - Calcium Hardness 200-400 ppm

- Activate the pumps from the Control Panel, page 10.
 - Keep the jets on and spa cover open when adding chemicals to ensure proper mixing. Leave your spa cover open to protect pillows and plastic knobs until the sanitizer level becomes stable.
- Add chemicals according to the product's label. Reference the Detailed Water Setup instructions, page 21.
- Establish and maintain a stable sanitizer reading of no less than 0.5 ppm (1.0 ppm if outside the US) free chlorine or 2.0 ppm bromine.
 - While the spa is heating, allow the hot tub to sit undisturbed. Retest the water after 8 hours or before usage to determine if the sanitizer levels are stable.
 - **If the sanitizer reading is unstable after adding the chemicals**, you may need to drain and refill the spa water to start over. See page 21. Any readings not within the recommended parameters are considered to be unstable.

Heating Your Spa

- Once the water chemistry is balanced allow your hot tub to heat.
- The spa will begin to heat to 100°F (37.8°C) automatically. This will take approximately 12-24 hours and will vary depending on the starting water temperature, ambient air temperature and hot tub size.
- The heater warms the water until it's about 1°F (0.5°C) warmer than the set temperature, then it turns off. It will turn back on once the water cools to about 2°F (1°C) below the set temperature.
- Keep the cover on when heating. When the spa is not in use, the cover locks should be locked to prevent unauthorized use, children from entering the hot tub, and for safety concerns, page 5.
- The cover should be in place anytime that the spa is not in use to save on operating costs and reduce heating time.

While you wait...

While the spa is heating up, you can continue learning about your spa and setting up other helpful features and preferences, including water settings.

Locating Your Serial Number

- You can find the serial number in many ways, Figure C:
 - On the Control Panel, tap the Profile name at the top of the screen, then All Settings. Tap About on the left side menu.
 - Scan the QR code label next to the Control Panel. This label also contains the spa serial number as a nine-digit number, i.e., 101012345 this is a sample serial number.
 - Remove the front cabinet panel to find the spa's name plate.
 - Reference "Download the SmartTub® app" (page 3) information to learn more about using the SmartTub® app.
 - Reference "Register Your Spa" (page 5) information to register your hot tub and activate your warranty within 7 days of installation.

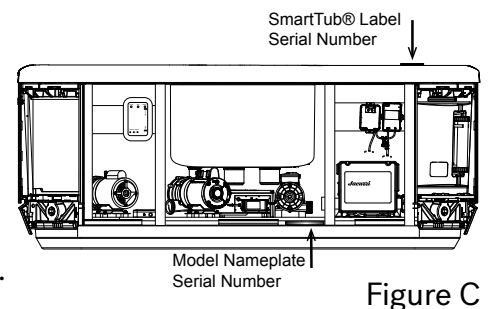
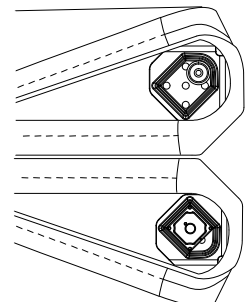


Figure C

Install the Cover Sensor

1. In the SmartTub app, tap "My Spa" in the menu.
2. From the My Spa screen, tap "Sensors."
3. From the Sensors screen, tap "Cover."
4. Once your sensor appears in the list on the screen, tap it and follow the instructions in the app to pair the sensor with the spa.
5. Press the button in the middle of the cover sensor to activate. Place the cover sensor in one of the brackets.
6. Place the insulating cover on the spa, open it halfway.
7. Unzip the lower half of the cover sleeve by a few inches.
8. Tuck the magnet and bracket inside the cover sleeve, lining it up with the corner.
9. Zip up the lower half of the cover sleeve.

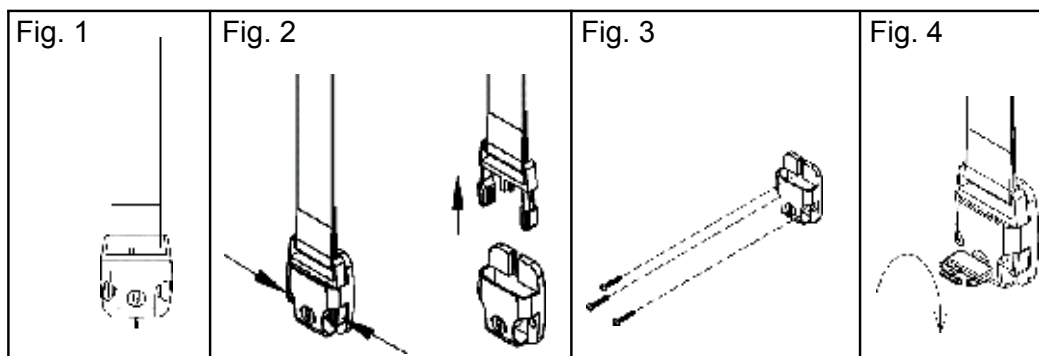


10. Now, unzip the upper half of the cover sleeve by a few inches.
11. Tuck the second bracket and cover sensor inside the cover sleeve, lining it up with the corner so that it lines up with the other bracket when the cover is closed.

Install the Cover Locks

Follow these steps to properly install the cover and locking straps. Many times this is a task that your dealer can perform for you.

1. Place the spa cover on top of the spa.
2. Ensure the cover flaps and straps are not under the cover.
3. Ensure the cover is properly seated in its final position.
4. Ensure that the seam of the cover is not over the control panel in order to prevent damage to the control system.
5. Secure the locking straps around the spa
6. Remove the bag containing the screws.
7. Lightly pull downward on a strap and mark the center bottom of the latch (Figure 1). A piece of tape may be a good method to do this.
8. Mark each remaining strap in the same way.
9. Remove the strap by pinching the two barbs of the strap as indicated (Figure 2).
10. Hold the cabinet latch on the mark and using a Phillips screwdriver, drive three screws through the holes in the cabinet latch and into the outside of the spa (Figure 3).
11. While the spa is not in use, place the cover on top of the spa and snap all straps into the cabinet latches.
12. To further protect against entry and bad weather, lock each latch by quarter turning the key clockwise (Figure 4). Store the key in a secure place.



Register Your Spa

Registering is necessary to validate your warranty. Follow these steps to register your spa. Registration must be done within the 7 days from the date of installation.

1. Using your home computer or other device, connect to the Internet.
2. Go to www.Jacuzzi.com
3. Hover over *Support*
4. Click *Register Your Product*
5. Click *Register Your Hot Tub*
6. Enter your serial number
7. Follow the prompts to provide your information

Enjoying your spa

Before you begin

Remove the cover and check the water temperature. Ensure that the water is within a stable range. See page 21 in the True Water section for more information on water care.

Quick Start

Enjoying your spa is effortless.

- Step in, choose your favorite seat, select one of our curated modes, and let relaxation take hold. Reference the Get to Know Your Spa section (page 8) for more information about using the Control Panel to personalize your experience.
- Choose your Profile
 - Choosing your profile gives you access to the modes and tuning that are just for you. You can always change it by tapping your profile at the top of the screen. For more information about profiles see page 11.
- Choose your Mode
 - Modes have been carefully curated by Jacuzzi to give you the perfect Light, Jet, and Sound settings for your experience. Select a recommended mode from the home screen or tap Explore to see them all.
 - Want to customize the experience? Tap Tuning to adjust Lights, Jets and Infrared.
 - Tap the bookmark button in the top right to save your tuned settings as a new mode and make them easier to access next time.
 - See the Control Panel section to learn more about creating and saving modes, page 9.
- Choose your Seat – Each seat in your Jacuzzi spa has been carefully designed to serve a different need:



Infrared therapy seat

Back and foot relief

Our most advanced hydrotherapy—Infrared and Red Light—now has its own dedicated seat with four IR lights for full-back Infrared therapy, only on the J5. A soothing waterfall and rejuvenating foot jets heighten the experience.



MX therapy seat

The original in low-back relief

Ease into this deeply contoured seat to release tension in the lower back with a high-volume, low-pressure massage. Maximized air output delivers a soothing deep-tissue massage. Paired with neck jets for a fully relaxing experience.



RX therapy seat

Comforting back and shoulder relief

A ring of spinning RX jets targets back and shoulder muscles to soothe stiffness and release tension, while neck jets add further relief. It plays a vital role in our highest performing hydromassage.



ProAir™ seat

Neck, shoulder, and back relief

Delivers the best of both worlds, pinpointing muscles along the neck and shoulders, while also providing relaxing hydromassage to larger muscles down the back.



FX therapy lounge

Neck, shoulder, back, palm, hip, legs, and foot relief

Our most fully loaded lounge features an array of FX jets that deliver a stimulating, spiral-action massage targeting key tension areas. It's an immersive hydromassage experience that melts away muscle tightness, improves mobility, and promotes deep relaxation.

J509™



- 1 MX therapy seat
- 2 Infrared therapy seat
- 3 ProAir™ seat
- 4 FX therapy seat
- 5 Bench seat
- 6 RX therapy seat

J508L™

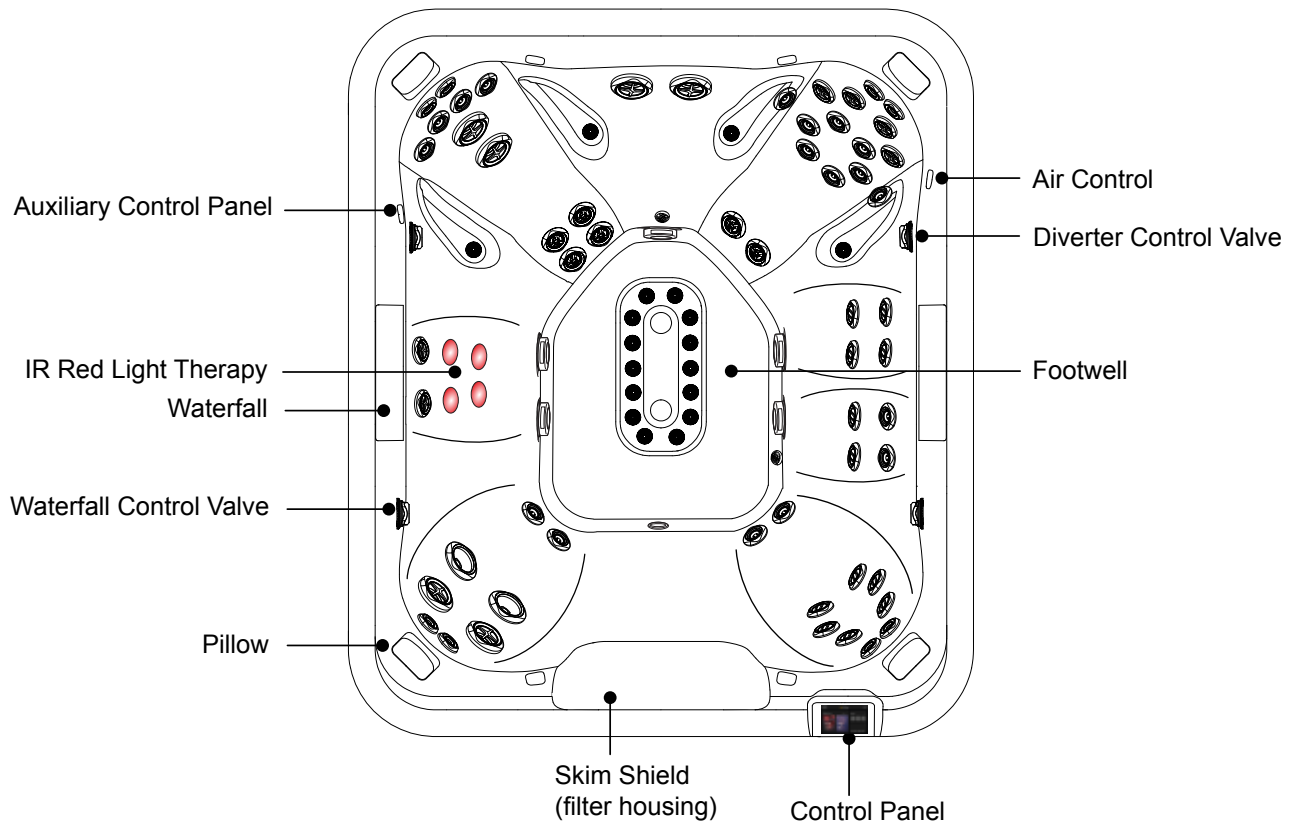


- 1 MX therapy seat
- 2 Infrared therapy seat
- 3 ProAir™ seat
- 4 FX therapy lounge
- 5 RX therapy seat

Get to Know Your Spa

Spa Overview

Review the diagram and descriptions below to get familiar with your spa's terminology.



Auxiliary Control Panel – this allows you to control your massage, lights, and IR therapy without needing to leave your seat to use the main Control Panel across the spa.

IR Red Light Therapy – these are patented lights providing the rejuvenating and regenerating benefits of deep red light and infrared light therapy across your mid to lower back.

Waterfall – this is one of two wide, flat sheets of water that cascades into the spa, the second is directly across the spa. Sit beneath the stream for a soothing sensation over the neck and shoulders or use it as a water feature to let the gentle sound of water movement set the ambiance in your space.

Waterfall Control Valve – rotating this valve increases or decreases the flow of water to the waterfall to create the experience that is just right for each moment.

Pillow – each primary seat has a cushioned pillow that adjusts up and down to fit your height and provides comfort as you relax into the seat.

Skim Shield – this shield streamlines the aesthetic of the spa and assists with water clarity by hiding your spa's filtration yet allowing water to efficiently flow into the system.

Control Panel – this is a highly intuitive touchscreen interface and is the primary controller of the spa. This gives you control of the overall experience and efficiency of the spa from creating user profiles to customizing usage schedules.

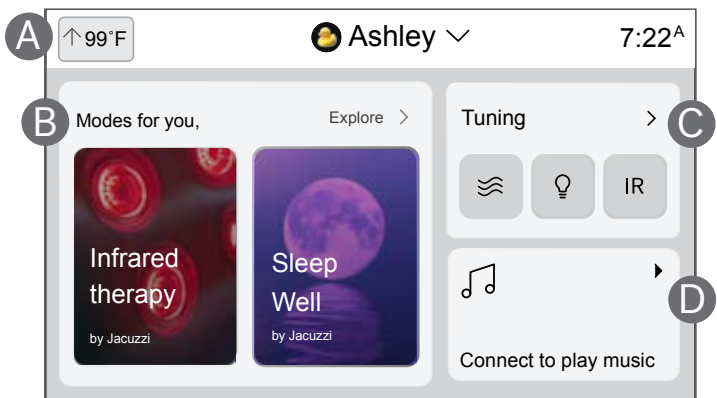
Footwell – reflexology is an integral part of the massage experience, and the footwell area allows each person to have a spot to rest their feet and feel jet therapy. This is also where the water will drain from when needed.

Diverter Control Valve – turn this valve to increase or decrease the massage power at your seat to fine tune your personalized experience. Water diverts front to back for side the diverter is located on.

Air Control – located at each primary seat, you can turn on or off air bubbles in your massage experience. Adding air softens the impact of the water while increasing the intensity of the massage. It gives your massage the power yet is gentle.

Interface Overview

From the home screen, you can manage Modes, Tuning, Sound, Temperature, and Profiles.

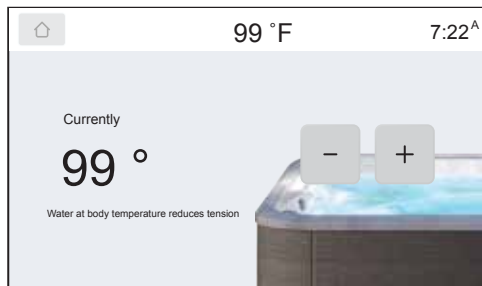


Note: After you wake the screen select the profile you want to use.

A. Setting your Temperature

The current temperature of the spa water is displayed in the top left of the Home screen, with an indication of when it's heating, cooling, or maintaining a temperature.

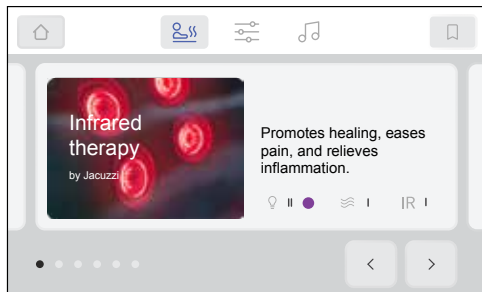
- To change the temperature, tap the temperature button on the home screen.
- Tap + or – on the screen to set the new temperature
- Once a new temperature is set, it will take some time for the water to reach it. If you are increasing the temperature, your hot tub will provide you an estimated time to reach the new temperature.
 - Please note that your spa does not have a cooling system by default, meaning that heating will stop and the water will take time to naturally cool. If you have had a heat pump installed on your spa, your spa will be able to cool more quickly.
- The temperature range for the spa is from 65°F (18.33°C) to 104°F (40°C). To activate the overtemp feature, see page 30.
 - Setting the thermostat at maximum will not accelerate the heating process. This will only result in a higher ultimate temperature.
- The heater warms the water until it's about 1°F (0.5°C) warmer than your set temperature, then it turns off. It will turn back on once the water cools to about 2°F (1°C) below your set temperature.



B. Choosing and Creating a Mode

Simplify your wellness journey with Modes, which provide quick access to your favorite tuning combinations. Enjoy modes curated for you by Jacuzzi or create your own. Tap a mode from the home screen to activate it or click Explore to scroll through a list of more mode options.

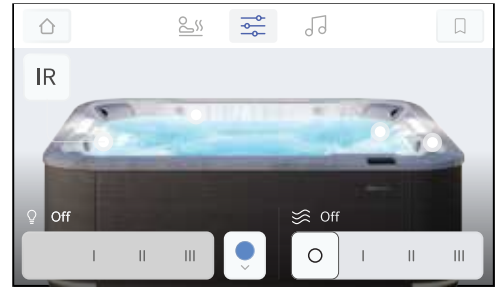
- In the list of modes, tap a mode to activate it. The lights, jets, and infrared settings of each mode are indicated below the description.
- To create your own custom mode, go to the Tuning Menu and adjust the lights, jets, and infrared settings based on your preferences. Then click the bookmark icon to save the tuned settings as a mode.
- To delete a mode that you've created, select the mode in the list and tap the bookmark icon.



C. Tuning your Hydrotherapy Experience

You can quickly turn on and off your lights, jets, and infrared therapy from the home screen by tapping the corresponding buttons. To change the settings, tap the Tuning Menu.

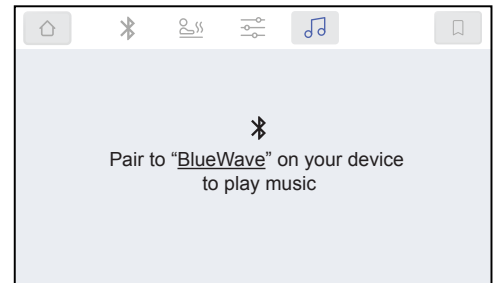
- **Hydromassage:** All of the jets are controlled together for an unmatched hydromassage experience. There are 3 levels of intensity: Gentle, Refresh, and Intense.
 - Jets can also be controlled by turning the Water Diverters, which can be found under the waterline around your spa.
- **Lights:** Choose between the three brightness levels on the tuning screen and select a color from the menu or you can select a Scroll Speed to have the colors change at one of three set speeds.
 - Syncing with sound will change the brightness with the intensity of the Sound that is playing.
 - Toggle off the waterfall lights to enjoy the underwater lighting only.
- **Infrared (IR):** Infrared + Red Light therapy is available in the IR seat. Turn this therapy on or off using the IR button on the home screen, the tuning screen, or the auxiliary control. Infrared + Red Light therapy will automatically turn off after 20 minutes.



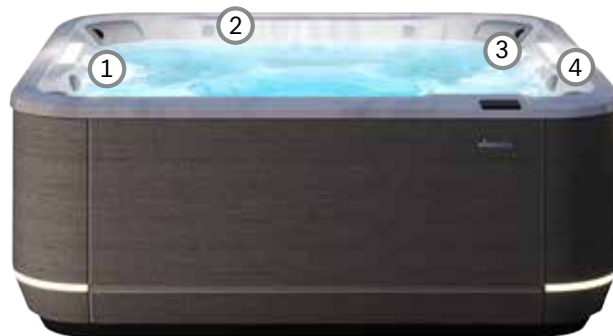
D. Sound and Soundscape

Connect to your personal device to play music.

- Tap the Sound Menu from the home screen to enter the Sound screen.
 - OR, touch the music icon from the Modes and Tuning screens.
- In your personal device's Bluetooth settings, pair to BlueWave. The pairing code is 0000.
- Once connected, adjust the volume and control the selected song from the Home or Sound screen.
- Play your media, or try a Jacuzzi soundscape, available through the SmartTub® app.



To learn more about Infrared Therapy, the Air Control Switch, the Water Diverter, and the Waterfall Control, touch the white circles on the spa diagram in the middle of the Tuning screen.



1. **Infrared and Red Light Therapy:** Experience these wellness technologies working beneath the skin to relieve lower back pain and improve range of motion.
2. **Air Control Switch:** Use one of these switches to turn the air on or off in the jets closest to the switch.
3. **Water Diverter:** These diverters are under the waterline. Turn them to increase or decrease the pressure of your hydromassage in your favorite seat.
4. **Waterfall Control:** Turn the waterfall on or off using the controls across from each other on your spa.

Managing Profiles & Settings

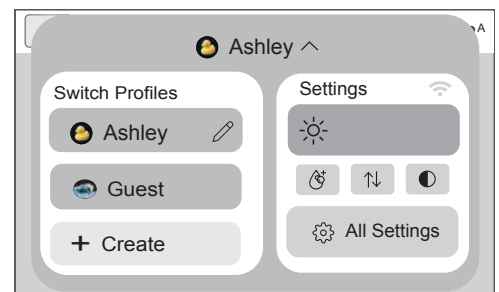
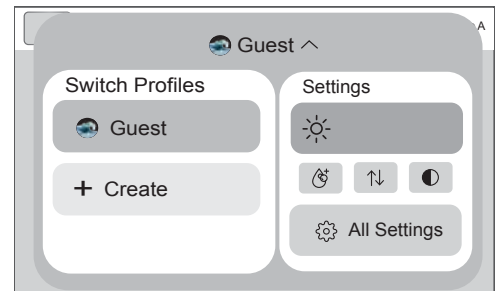
Tap the Profile name at the top of the Home screen to access Profile Management and Settings. From this screen, you can switch profiles from the list on the left or quickly adjust common settings on the right like control screen brightness, style, and orientation. Tap Settings to access all settings for the spa, water care, troubleshooting, and spa security options.

The unique customization of your J5 spa allows you to create separate profiles for your own personal experience. This allows you to use the presets already tuned for you or you can tune the settings to be just right for you. The control will remember the settings used from your last session and you can also save the settings in your own profile so that everyone using the spa can have their own tailored experiences.

Profiles

To access Profile Management, tap the Profile name at the top of the Home screen.

- To add a new Profile:
 - Scroll to the bottom of the list of existing profiles and tap “Create”. Choose your preferred image and type a name for your profile.
 - Tap “Create” to save the profile.
- To edit a Profile name or image:
 - Tap the pencil icon next to the profile.
 - Choose a new icon or type a new profile name.
 - Click Done.
- To switch to a different Profile:
 - Tap a Profile name in the Switch Profiles list.
- To delete a Profile
 - Tap the pencil icon next to the profile.
 - Tap Delete.
 - Tap Delete in the pop-up box to confirm your choice.



Settings

To manage Settings, tap the Profile name at the top of the Home screen. This provides quick access to the most common settings. Allows you to adjust the brightness, activate the waterfall and boost option for the True Water® system, flip the display, or change display modes. To access more settings, tap the "All Settings" button. Below lists all the controllable features. Most settings have on-screen descriptions for what the feature controls.

- In the General section you'll find:
 - Information about your spa
 - A path to download the SmartTub app
 - Wi-Fi settings
 - Sleep timer settings
 - Date & time settings
 - Language preferences
 - Temperature units preference
 - Exterior lights
 - See the Spa Programming section in this manual for more information on adjusting these settings.

- In the Spa Care section you'll find:
 - Heat Mode options
 - Water care settings
 - Reminder settings
 - See the Spa Programming section in this manual for more information on adjusting these settings.
- In the Security section you'll find:
 - Locking options for various settings
- In the Troubleshooting section you'll find:
 - System Information
 - Error Messages
 - System Tests
 - Links to the manual
 - Contact Information
 - Service Hold settings

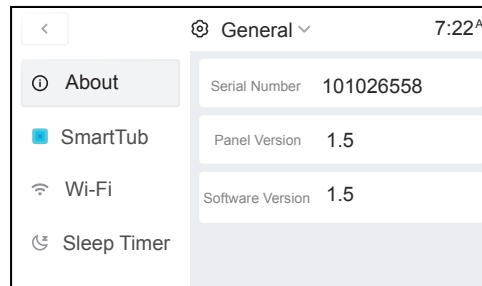
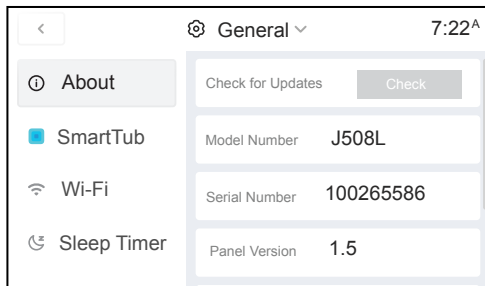
Spa Programming

There are several aspects and features that can be programmed that help you enjoy and manage the care of your hot tub.

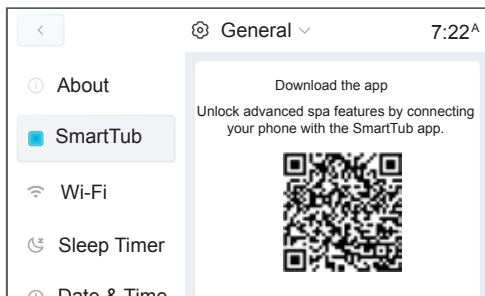
Follow the steps displayed on the control panel to make any adjustments or programming changes.

General Menus

- **About**
 - Allows you to check for software updates.
 - Displays information about the hot tub.
 - Displays the control panel software revision.

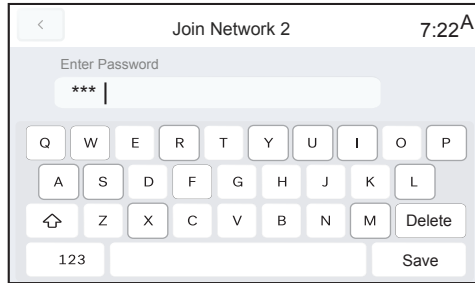
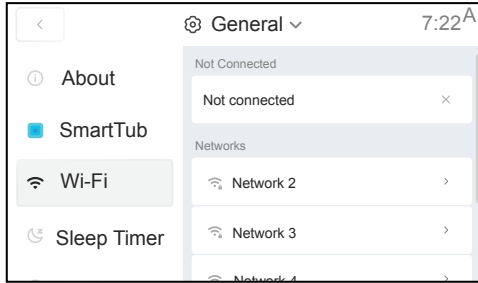


- **SmartTub®**
 - Scan the QR code to install the app on your phone.
 - Follow the instructions on the SmartTub® app.



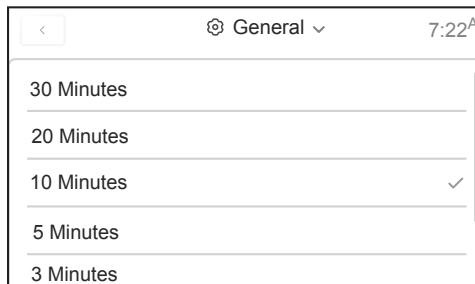
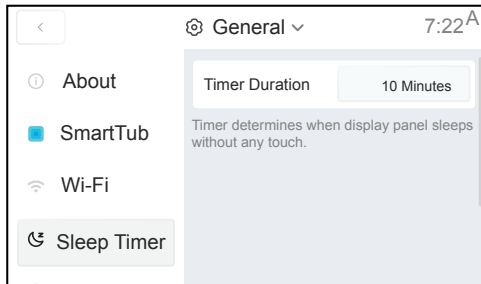
- **Wi-Fi**

- Input your network information to connect via Wi-Fi.



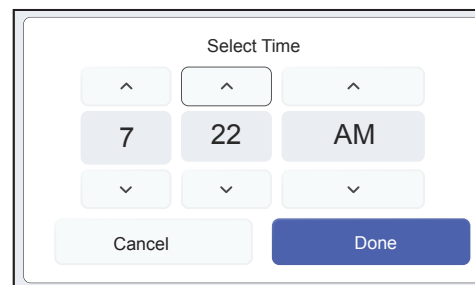
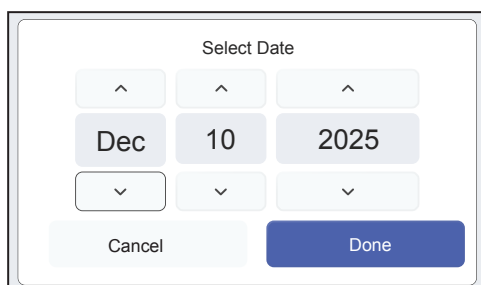
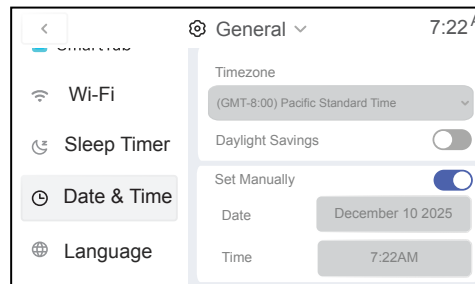
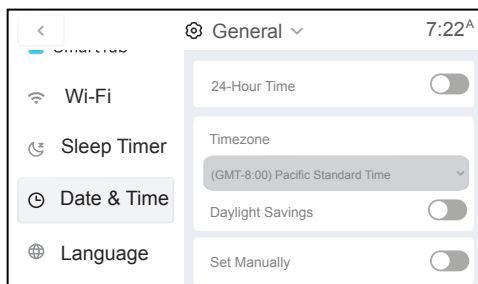
- **Sleep Timer**

- Set the timer to allow the control panel to go to sleep after a set amount of time of inactivity.



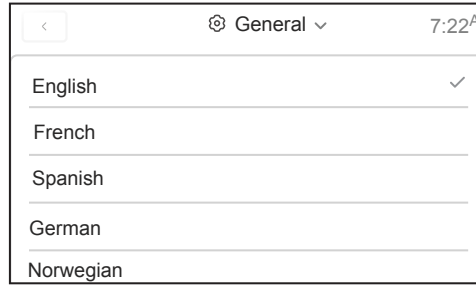
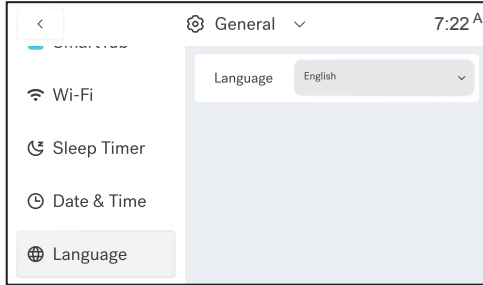
- **Date & Time**

- Choose the time format to display.
- Set your time zone.
- Allow for daylight savings time adjustment.
- Set the date.
- Set the time.



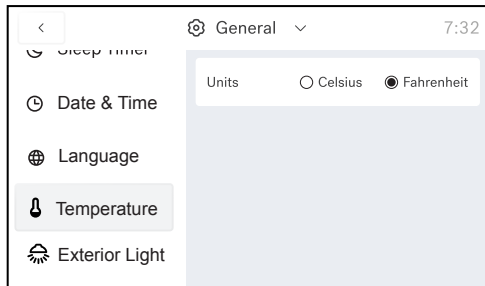
● Language

- Select the language to display.



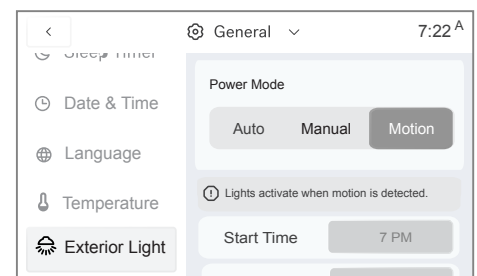
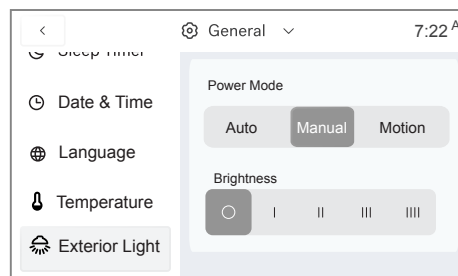
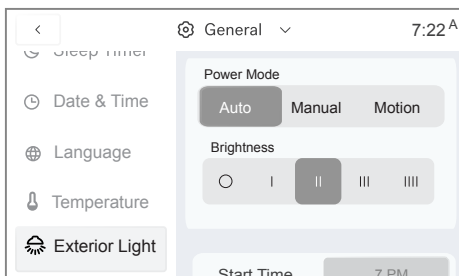
● Temperature

- Select the temperature display format.



● Exterior Lights

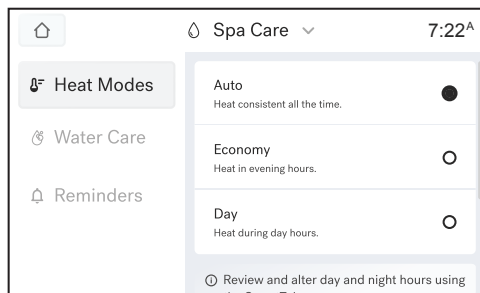
- Auto: Activates the lights. The lights can be programmed to activate during a certain time period by setting a start and end time.
- Manual: Activate the lights at any time.
- Motion: The lights are on at low brightness. Lights brighten for 5 minutes when motion is detected by the sensor. The sensor has a 10-foot range. The lights can be programmed to activate during a certain time period by setting a start and end time.
- Tap to select one of the four Brightness levels. Feature is only available for the Auto and Manual Modes.



Spa Care

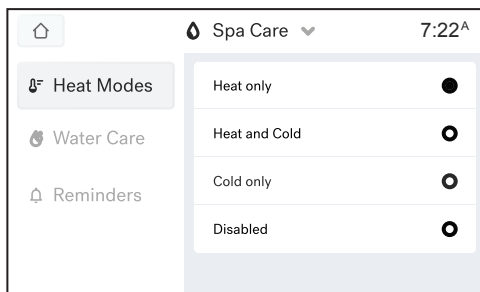
Heat Modes

- **Auto Setting:** The hot tub maintains the water temperature to the programmed setting.
- **Economy Setting:** The hot tub is only allowed to heat from 5:00 pm to 7:00 am.
- **Day Setting:** The hot tub is only allowed to heat from 7:00 am to 5:00 pm.
- When a heat pump is installed, you can also set the settings.



Heat Modes (when Heat Pump is installed)

- **Heat only:** The hot tub is allowed to only heat the water.
- **Heat and Cold:** The hot tub is allowed to heat or cool the water.
- **Cold only:** The hot tub is allowed to only cool the water.
- **Disabled:** The heat pump is disabled.

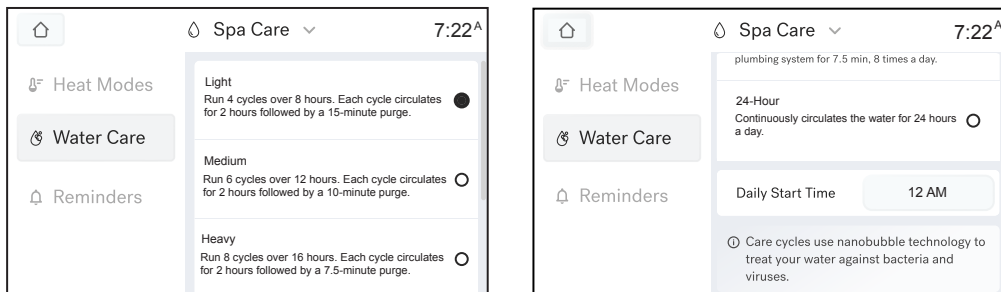


Water Care

The start time for all cycles is 12:00 am but it can be changed to a desired start time. You can choose one of the cycles depending on your needs.

- **Light Cycle (default cycle 8 hours of filtration):**
 - The factory default cycle starts at 12:00 a.m. and provides 8 total hours of filtration. Time and duration cannot be altered.
 - 8 hours of filtration per day (2 hours every 6 hours). The circulation pump and True Water® Care System are active.
 - 4 purge cycles (15-minute purge runs at the end of each cycle). The circulation pump and air pump are active.
- **Medium Cycle (12 hours of filtration):**
 - The cycle starts at 12:00 a.m. and provides 12 total hours of filtration. Time and duration cannot be altered.
 - 12 hours of primary filtration per day (2 hours every 4 hours). The circulation pump and True Water® Care System are active.
 - 6 purge cycles (10-minute purge runs at the end of each cycle). The circulation pump and air pump are active.

- Heavy Cycle (16 hours of filtration):
 - The factory default cycle starts at 12:00 a.m. and provides 16 hours of filtration. Time and duration cannot be altered.
 - 16 hours of primary filtration per day (2 hours every 3 hours). The circulation pump and True Water® Care System are active.
 - 8 purge cycles (7.5-minute purge runs at the end of each cycle). The circulation pump and air pump are active.
- 24-Hour
 - The circulation pump and True Water® Care System are always active.
 - Time and duration cannot be altered for the cycle.
 - System runs 24 hours.
 - In extreme bitter cold weather we recommend you program the circulation pump to run 24 hours. Refer to the “Winterizing” section on page 26.



IMPORTANT NOTE: Any time the circulation pump runs outside of a program cycle, e.g. for heating, that run time will be deducted from the next filter cycle. For example, the factory filter cycle is set to 8 hours total and starts every 6 hours. If the circulation pump comes on for 1 hour to heat the water, the next filter cycle will only be for 1 hour not 2 hours.

Cleaning Boost Cycle

Tapping the Cleaning boost feature activates the True Water® Care system. To enter the Water Care Menu. Tap + Boost activate the system for 1 hour. During this time the circulation pump and the True Water® Care system are on.

Note: When the True Water® Care system is on due to a programmed or scheduled setting the feature cannot be turned off.

Cleanup Cycle

The cleanup cycle occurs once per day at 12:00 pm (noon) and automatically activates the pumps for 1 minute. This is not user programmable.

For a 2-pump system: Pump 1 and 2 (low speed) and Circulation Pump will turn on for one minute and then shut off.

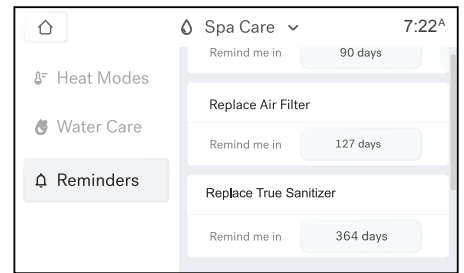
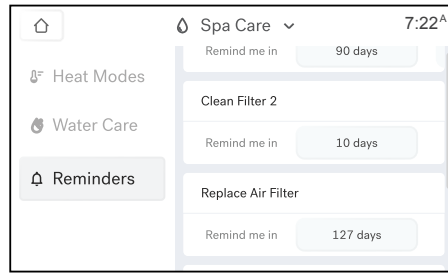
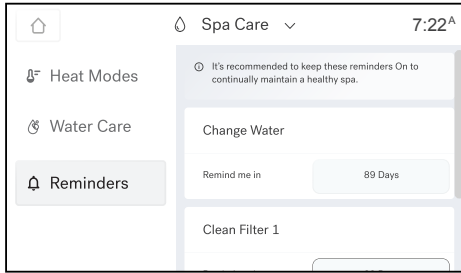
For a 3-pump system: Pump 1 and 2 (low speed), Pump 3 (high speed) and the Circulation Pump will turn on for one minute and then shut off.

Reminders

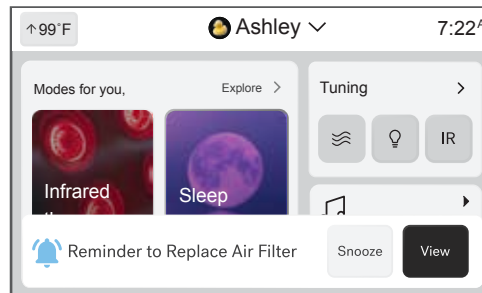
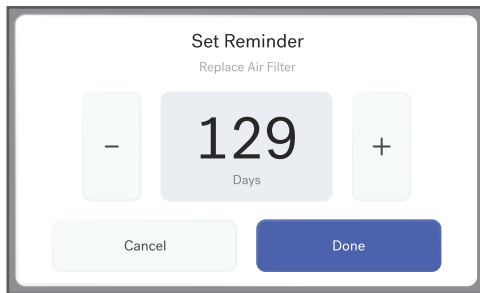
There are several reminders that can set to appear when maintenance or a replacement is needed.

- Change Water: Program the reminder from 10-180 days. Once it expires you will need to change the water and reset the timer. Default setting is 180 days.
- Clean Filter 1: Program the reminder from 10-180 days. Once it expires you will need to clean the ProClear filters and reset the timer. Default setting is 180 days.
- Clean Filter 2: Program the reminder from 10-90 days. Once it expires you will need to replace the ProClarity filter and reset the timer. Default setting is 90 days.
- Replace Air Filter: Program the reminder from 10-180 days. Once it expires you will need to replace the True Air Filter and reset the timer. Default setting is 180 days.

- **Replace True Sanitizer (Ozone):** Program the reminder from 10-730 days. Once it expires you will need to replace the True Sanitizer (Ozone) and reset the timer. Default setting is 730 days.



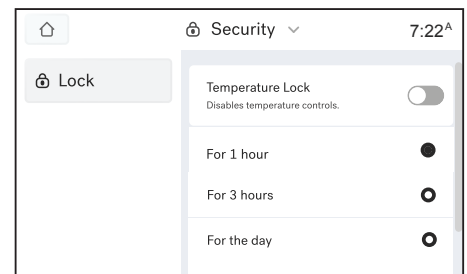
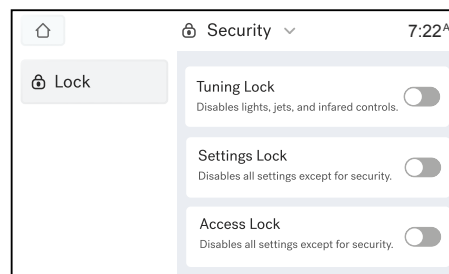
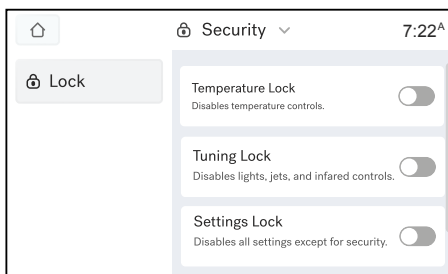
- To program the days, tap the "days" button to enter the programming menu.
- When the timer expires, a message will display on the Home Menu.
- If snooze is selected, the reminder will reappear in 10 days.



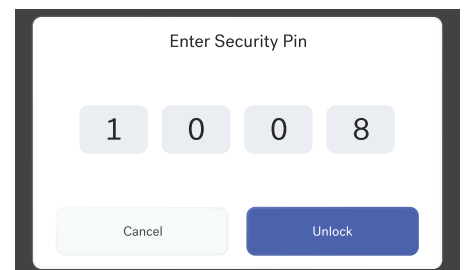
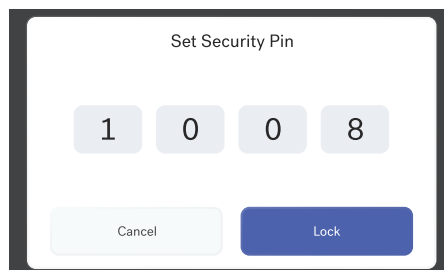
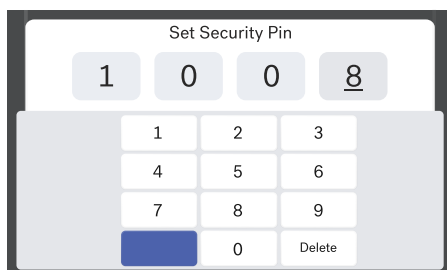
Security

- **Locking Settings and Features**

- **Temperature Lock:** Disables the temperature settings to prevent any changes.
- **Tuning Lock:** Disables the lights, jets, and IR Therapy lights.
- **Setting Lock:** Disables all the settings except for security.
- **Access Lock:** Disables all the settings except for security.
- When certain settings are locked, a small lock icon will appear next to the settings locked.



- When you activate the tab for the settings you want to lock you will be asked to enter a 4-digit code. Then tap "Lock."
- To unlock the features, tap the settings you want to unlock, enter the code, and tap "Unlock."
- A default code of "0772" can be entered if the security code is lost or forgotten.



Troubleshooting

● System Information

- Provides various information about your hot tub. This menu is intended for Technicians.

● Messages

- Displays a message log for any notifications.

● Tests

- Allows you to test the GFCI for proper function and safety. If the GFCI fails, DO NOT ENTER THE SPA! Contact your authorized Jacuzzi dealer.

● Manuals

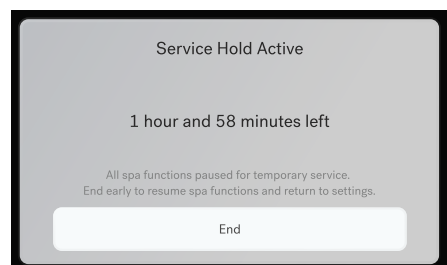
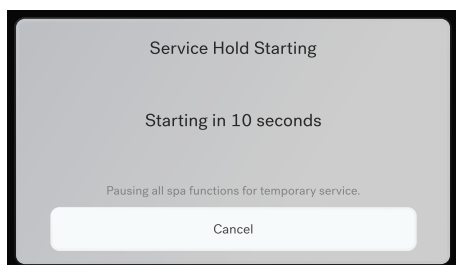
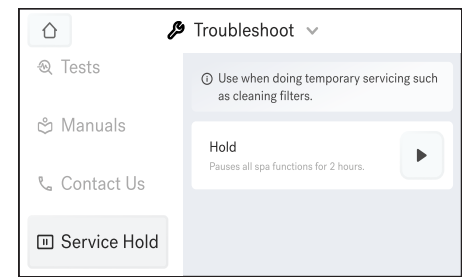
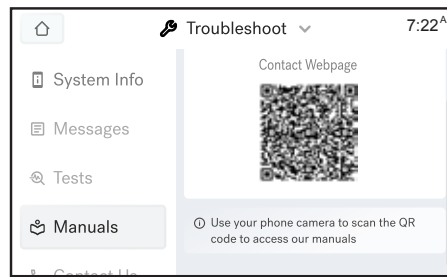
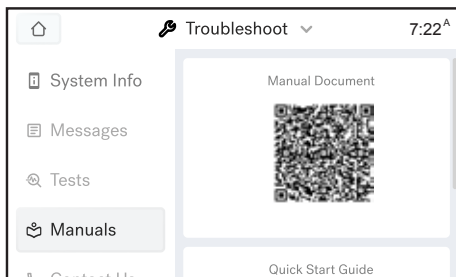
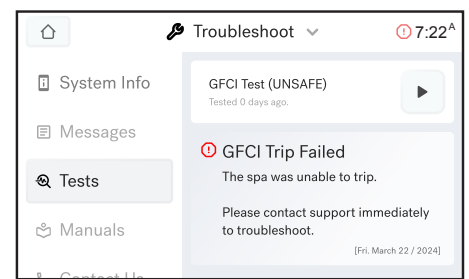
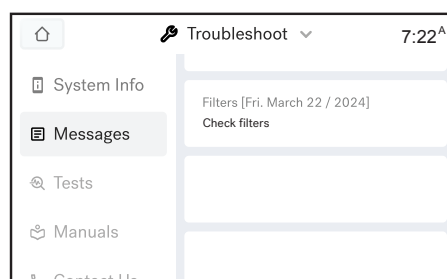
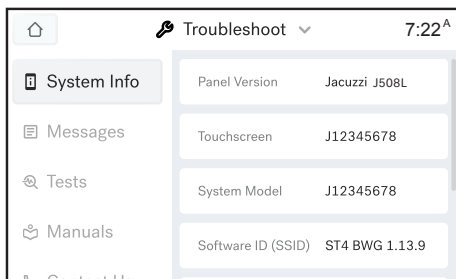
- Scan the QR code to access the owner's manual.

● Contact Us

- Scan the QR code or dial the phone provided to reach us.

● Service Hold

- Puts the hot tub in a service hold for 2 hours. None of the settings or features will function. You can use this to service or clean the filters.
- **Note:** if you are experiencing freezing temperatures make sure to take precautions so no damage occurs to the hot tub.



Spa Maintenance

Your J5 is equipped with our True Water® system that brings a world-leading clean¹ water technology system to home spas. True Water makes spa water fresh and clear without all the harsh chemicals. Trillions of oxygen-filled nanobubbles continuously scrub away contaminants² to deliver clear, sparkling water that is 99.9999% chlorine-free. That's even less than drinking water.³ You'll see, feel, and smell the difference. Scan to learn more about how True Water is revolutionizing water care.



¹Clean is defined as the removal of microscopic dirt and debris (down to 3-micron level, varies by model) from the water. ²Contaminants include dirt and grit. ³Spa water is meant for soaking, not for sipping. Spa Care section for troubleshooting instructions, page 21.

To ensure healthy water conditions, always maintain a constant sanitizer reading. This will help decrease the risk of contracting a waterborne illness (e.g. an infection, bacteria or virus) and/or respiratory ailments, maintain water quality within specified limits. This will enhance your enjoyment and prolong the life of the hot tub's equipment. Doing so requires regular attention because the water chemistry involved is a balance of several factors. Procrastination in regard to water maintenance will result in poor and potentially unhealthful conditions for soaking and even damage to your spa investment. For specific guidance on maintaining water quality, consult your authorized Jacuzzi dealer who can recommend appropriate chemical products for sanitizing and maintaining your hot tub.

We build our hot tubs to be as reliable as they are relaxing. They're engineered to perform with high-grade materials and precision crafted components—all rigorously tested for lasting enjoyment, year after year, with minimum upkeep. Proper maintenance will enhance your enjoyment and prolong the life of your spa.

Compliance with Local Water Treatment Regulations

Spa owners must test and treat spa water in compliance with all applicable local health and safety codes. Local authorities may specify water quality parameters, disinfection methods, or testing frequency beyond those provided in this manual. It is the responsibility of the spa owner to consult and follow local code requirements for water quality management.

Maintenance Schedule

The following schedule is a baseline for how to care for your spa over time after the initial setup. Depending on the frequency of use and other factors, you may need to adjust the timelines slightly. Contact your authorized Jacuzzi dealer for specific guidance on maintaining water quality and for recommended chemical products.

To make upkeep simple, your control panel displays maintenance notifications when service is recommended based on chosen reminder schedule. When a reminder appears, you can choose to snooze or reset it for next time. Reminders can be managed from the Spa Care section of the Settings screen.

Every Week

- Test your water to ensure the readings fall within the recommended parameters.
- Manage your water chemistry based on the reading. Refer to the Spa Water Care Instructions.
- Test Your Spa Water
- Test your spa water using the same procedures as the initial setup.

Every Month

- Rinse and clean both ProClear filter cartridges
- Check and empty the ProClarity debris basket
- If using the Frog® cartridge products @ease® or Serene™, check and replace the sanitizer cartridge
- Rinse the cover to remove any debris

Every 3 Months

- Replace the ProClarity Polishing filter
- Drain & Refill your spa

Every 6 Months

- Replace the True Water® air filter.

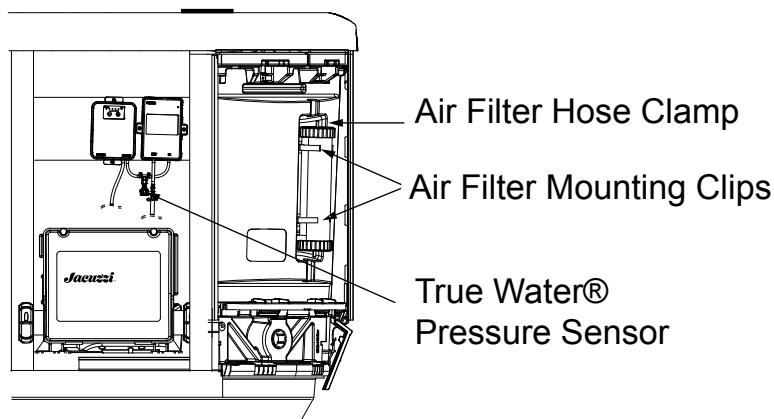
Every 18 Months

- Replace both ProClear filter cartridges

As Needed

- Clean each pillow
- Clean the Spa Exterior & Control Panel
- Clean the Spa Interior

Changing the Air Filter and Sensor Battery for the True Water® System



Air Filter

The Air Filter will need to be replaced every 6 months. To replace the filter follow these steps:

1. Turn power off to the spa!
2. Loosen the hose clamp.
3. Grab the air filter and gently pull on it to unsnap from the holding clips.
4. Pull the air hose off the air filter bib.
5. Install new Air Filter.
6. Attach air hose to the air filter bib.
7. Snap the new filter into the mounting clips.
8. Tighten hose clamp over the hose and bib.
9. Turn power on to the spa.
10. Reset the reminder on the control screen or in the SmartTub® App

Pressure Sensor

The indicator in the SmartTub® app will tell you when it's time to replace the Pressure Sensor battery. To replace the battery, follow these steps:

1. Turn power off to the spa!
2. Unscrew the sensor cap. This will expose the battery compartment.
3. Replace old battery with a new battery (Model # CR1632).
4. Screw sensor cap back on.
5. Turn power on to the spa.

Spa Water Care

Here's a more detailed breakdown to properly set your water:

1. Sanitizer:

- With the Jacuzzi True Water® system, you have a couple options to maintain the lowest amount of sanitizer of any spa. It is important to note that a residual of sanitizer in your spa is needed to ensure the efficient operation of our water treatment system. This prevents undue strain on your True Water® system to keep up with the natural demand for sanitizer of hot water even without usage.
 - Jacuzzi® brand's proprietary Frog @ease® system is a simple and easy way to start the system with low doses of Chlorine. Follow the @ease procedures found on the box. The True Water® system message of 99.9999% chlorine free is based on using this system, which self-regulates sanitizer level to 0.5 ppm without manually adding any chlorine. Additionally, this helps save time, as it only takes about 15 min of maintenance per month, including a cartridge change every 3-4 weeks. Cartridges may last longer when used in combination with your True Water® system.
 - Use of Chlorine by itself is also a great option. First, make sure the spa is up to temperature, and that alkalinity and pH are balanced. Then, add 1 oz. of granulated chlorine. Using standard chlorine requires monitoring to ensure the chlorine levels remain at a minimum of 0.5 ppm (1.0 ppm outside the U.S.), so be sure to use test strips that measure this low level of chlorine.
 - Bromine is another sanitizer option. You can use this in many forms, including a cartridge-based system like @ease SmartChlor™ which is called Serene™. Follow the instructions on the product label to ensure the proper dosage. For use with True Water®, monitor and ensure the bromine levels remain at a minimum of 2.0 ppm.

2. Total Alkalinity:

- Always adjust alkalinity first.
- Total Alkalinity Increaser: Add this to increase the alkalinity level.
- Target Alkalinity: Maintain an alkalinity level between 80 and 120 ppm.

3. pH Adjusters:

- pH Increaser: Use this to raise the pH if it's too low (below 7.2).
- pH Decreaser: Use this to lower the pH if it's too high (above 7.8).
- Target pH: Maintain a pH between 7.2 and 7.8 for optimal sanitizer effectiveness.

4. Calcium Hardness:

- Calcium Hardness Increaser: Use this to raise the calcium hardness if it's below 150 ppm to prevent erosion and corrosion.
- Target Level: Aim for a calcium hardness between 200-400 ppm.

5. Metal Remover:

- If you're using water from a source other than residential tap water or a water truck, consider adding a metal remover to prevent staining and discoloration.

6. Phosphates:

- If you test and have Phosphates in your water, add 1 oz. of Spa Phosphate Remover weekly to 500 gallons of spa water to keep phosphates low. For high phosphate levels of 1,000 ppb or more, add 3 oz. and test for phosphate levels the following day.
- Recommended phosphate levels in a spa are below 125 ppb.

7. Optional but Helpful:

- Shock:
 - A shock treatment (chlorine or non-chlorine) can be used to further sanitize the water and remove impurities. This is used sparingly with the True Water® system at approximately 1-2 oz. per month.
 - When using the @ease SmartChlor system, use one pack of the “Maintain” product once every 3-4 weeks when you replace the SmartChlor cartridge.
- Purge:
 - A purge treatment on the first-time start-up for your new spa is a great way to ensure all plumbing is reset from transit to your backyard.
 - If you have winterized your spa, a purge also will help to reset your plumbing.
- Test Strips/Kit:
 - Ensure your water chemistry is balanced by using test strips weekly.

8. Initial Circulation + Filtration:

- Upon fill for a spa with True Water® Nanobubble technology, you will see contaminants breaking up very quickly. This may cause your water to appear murky at first. We recommend cleaning the filters every other day for the first 2 weeks, or until the water remains pristine and clear.
- Set the circulation pump at the 24-hour setting to ensure the water clears.
- Replace the ProClarity filter after the first 3 weeks.
- After the initial fresh fill, the circulation pump can be set back to one of the 3 preprogrammed cycles (Light, Medium, or Heavy) depending on usage, see page 15. The best selection depends on how many people use the spa at once and how frequently it is used. The more you use the spa, the more filtration will help clear the water.

Important Notes:

- Follow manufacturer’s instructions:
 - Always follow the instructions on the chemical containers for proper dosages.
- Test water regularly:
 - Use test strips or a test kit to monitor your water chemistry and adjust chemicals as needed, keeping in mind that some are not calibrated to show low levels of chlorine or bromine.
- Adding Chemicals:
 - Run your spa’s jet pump(s) while adding any chemicals to ensure the chemicals are properly mixed and circulated.
- Safety:
 - Always use caution when handling chemicals and wear appropriate safety gear (gloves, eye protection).
 - Keep all chemicals out of reach of children.
 - Keep the spa cover open during this period. Fumes created during the initial mixing may damage pillows and knobs.

Manage Your Water Chemistry

Proper water chemistry maintenance is essential for the best spa experience. Your authorized Jacuzzi dealer can provide recommendations for the right chemical products and procedures for your region.


Your water chemistry should always fall within the following parameters:

- pH 7.2-7.8
- Free chlorine 0.5ppm (1 ppm outside the US)
- Free bromine 2 ppm
- Total Alkalinity 80-120 ppm
- Calcium Hardness 200-400 ppm

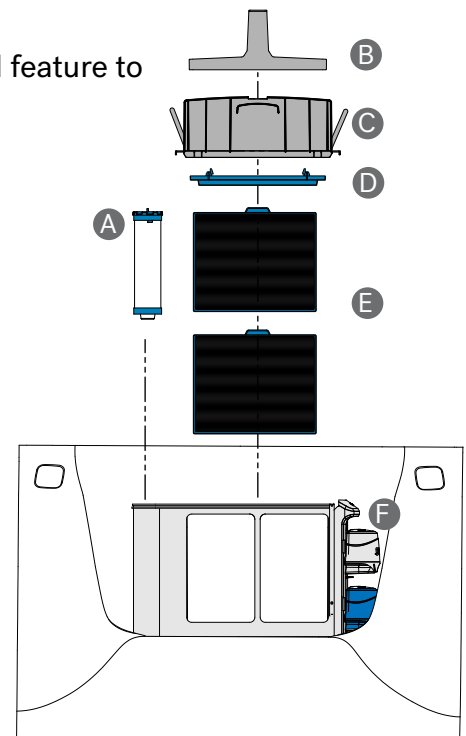
When adding spa shock (chlorine or non-chlorine) or pH balancing chemicals activate the jet pumps by tapping an experience mode on the control screen and leave the spa cover open for a minimum of 20 minutes to allow excessive chemical vapors to exit the spa. Do not leave the spa unattended when uncovered.

- Leave the spa uncovered and turn on the jets, turn on all air controls, and rotate all massage diverter control valves in their center position for one hour.
- While the spa is uncovered, you'll need to restart the jet pumps every 20 minutes, as they automatically shut off.
 - If spa is indoors, open door and windows for proper ventilation.
- If the sanitizer reading is unstable after adding the chemicals, you will need to reset the spa by draining the tub, page 25.
- Fill your spa again, page 1.

Clean the Filters

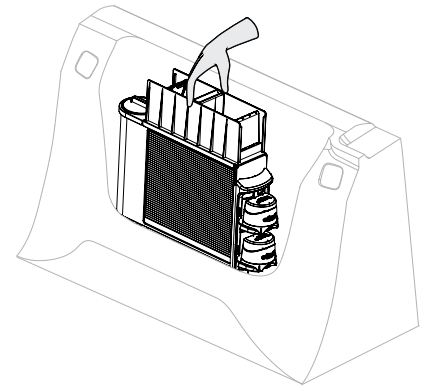
 **WARNING!** Turn power off to the hot tub or use the service hold feature to deactivate any spa functions, page 18.

- A. ProClarity Polishing filter (P/N 6542-083J)
- B. Skimmer Tray
- C. ProCatch Debris basket
- D. ProCatch Mesh screen (P/N 6542-178)
- E. ProClear filters (P/N 6542-082J; Qty 2)
- F. Frog® @ease® system (P/N 6570-725 Clip)



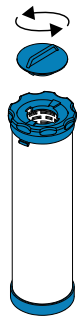
Empty the ProCatch debris basket and skimmer tray

- Gently squeeze both ends of the skimmer tray handles together and pull up to remove it.
- Then squeeze both of the large gray filter basket tabs together and pull up.
- Remove or rinse out any debris.
- Place the basket back into the filter area until it clicks back into place.



Replace the ProClarity Polishing filter

- Unscrew the cylindrical filter from the filter area. It will take about a half a turn to release the locking clips.
- Discard the used filter into a normal trash bin.
- If a ProClear mineral stick is used, remove the filter cap, by turning just the cap about a quarter turn and replace the stick as needed.
 - **Note:** Do not attempt to clean the ProClarity Polishing filter.



ProClarity Polishing filter

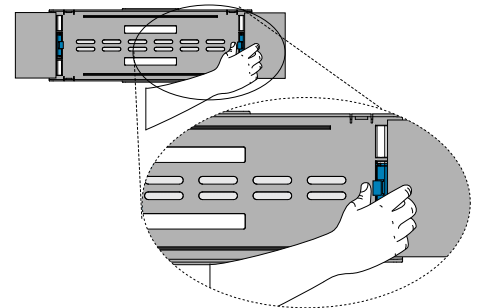
Clean both ProClear filter cartridges

Clean the filters after heavy use or when the reminder expires. The ProClear filter cartridges must be replaced every 18 months.

- Remove the ProCatch debris basket following the steps above.
- Remove each ProClear (flat) filter cartridge by pulling them upward
- Rinse away any debris trapped in the pleats of the filter.
- Filter cleaner solution is also available for a deeper clean. Fill a bucket with water and the designated amount of cleaner listed on the bottle. Soak the filters in the bucket overnight or as designated by the bottle.
- Rinse both filters thoroughly with normal water before placing them back in your spa.
- Replace the filters into each slot of the filter area.

Replace or Clean the ProCatch Mesh filter

- With the ProCatch basket removed, reach inside to locate the ProCatch Mesh Filter clips.
- Push the clips gently back to release the filter from the basket. Repeat the step on the other end of the basket.
- Reinstall (after cleaning) or replace the ProCatch Mesh Filter.



Clean the Spa Cover

ProLast covers distributed by Jacuzzi hot tubs are stylish and durable.

Regular monthly cleaning is strongly recommended and may increase the longevity of your cover.

To clean the cover:

- Use a garden hose to remove any debris.
- Using a large sponge or soft bristle brush, use diluted or mild soap to gently scrub the top.
- Rinse and clean and do not allow soap to dry on the cover. Do not use soap on the underside of the cover.
- To help increase the longevity of your cover: Remove any debris that accumulates on the spa cover to avoid breakage of the foam cores.
- Keep the spa covered and lock the cover straps when not in use.
- Do not place heavy objects on the cover, or walk, sit or stand on it.
- When removing the cover, use only recommended cover lift systems and ensure that all locks have been released to avoid damage. Do not drag or use the flaps/skirt or the cover lock straps to remove the cover.

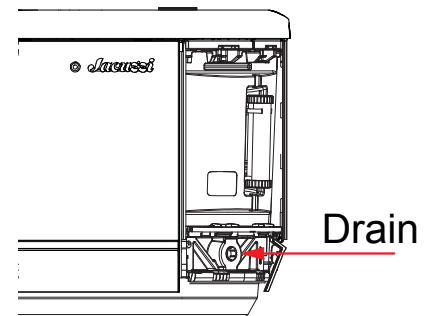
- Do not expose the interior of your spa to the sun for extended periods of time as UV rays can damage the surface.
- Do not use any solvents, abrasive cleaners or strong detergents.
- Do not use products that contain silicone or alcohol.

Draining the Spa

Consider the outdoor temperature before draining. When the spa is empty during extreme cold, freezing could occur in the lines or equipment. During extreme heat, the empty spa interior surface should not be exposed to direct sunlight.

Depending on the frequency of use, number of users, and level of water chemistry care, you may need to drain and refill your spa more often. We recommend draining and refilling every 3 months. You will know it is time for a change when you cannot control sudsing and/or you can no longer get the normal feel or sparkle to the water.

- Turn off the power to the spa at the breaker!
- Remove the front right corner panel and locate the drain valve, page 32.
- Hold the larger (rear) drain valve body to prevent it from turning, then loosen and remove the front cap to expose the underlying male hose threads.
- Attach a garden hose to the exposed threads.
- Gently rotate the larger (rear) valve body 1/3 turn counterclockwise to unlock the drain valve.
- Pull the larger (rear) body outward to open drain.
- After the spa drains, perform these steps in reverse order to close the drain prior to refilling spa.



Refill the Spa

Don't fill your spa from a water softener, as this may be corrosive to metal components. If your water is extremely hard, you can fill halfway with hard water, and the rest with soft.

- Refer to page 1 (Fill Your Spa) for filling instructions.

Pillow Care

- Remove and clean the headrests in your spa as needed by wiping them with a cloth with soapy water.
- To remove headrests for long-term storage or replacement, grasp both ends of each headrest and gently pull inward towards the center of the spa. To reinstall, align the pillow slot over the mounting posts and press until the pillow snaps into place over both posts.

Cleaning the Spa Exterior & Control Panel

- The synthetic cabinet requires little or no maintenance. To clean, simply wipe cabinet with a mild detergent soap solution and a clean towel.
- To clean the control panel, simply wipe with a micro-fiber cloth, similar to what would be used for cleaning polycarbonate glasses.

Cleaning the Spa Interior

- This should be done when the tub is empty to preserve the sheen of your spa's surface. Avoid using abrasive cleaners and assure that no soap residue is left before refilling.
 - Contact your authorized Jacuzzi dealer for more information on the right cleaners for your spa. We recommend Jacuzzi's hot tubs All Purpose Cleaner.

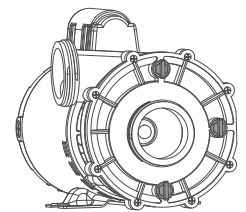
Winterizing

Your Jacuzzi spa is designed to operate in cold temperatures. However, in cases when the temperature is below 32°F (0°C), we recommend that you check the electrical supply to your spa to ensure it hasn't been interrupted. In these cases, you should also set the circulation pump to 24-hour operation and ensure that auto heating is selected to protect your spa from damage.

If you do not intend to use your spa during a cold season, or if there is a prolonged power outage during periods of severe freezing temperatures, it is important that all water be removed from the spa and equipment to protect against damage from freezing. Damage from freezing is not covered under the manufacturer's warranty.

Expert winterization of your spa is highly recommended; contact your authorized Jacuzzi dealer. In emergency situations, taking the following steps can minimize damage:

- Follow the directions on page 25 for draining the spa.
- Turn the massage/diverter selector(s) into the middle combo position to allow the water in the plumbing lines to drain, page 10.
- Turn the waterfall valve to the open position to allow the water in the plumbing lines to drain, page 10.
- As the water level drops below the seats, use whatever means necessary to get the water out of the recessed seating areas and into the footwell, such as a wet/dry vacuum. A pillow also can often help you scoop water out of the recessed seats.
- Open all the air controls and leave them open until you resume use of the spa, page 10.
- When the water level ceases to drop, use whatever means available to remove any remaining water from the footwell, such as a wet/dry vacuum.
- Remove the corner panels, then the front cabinet panel and locate the drain plugs in the front of each pump. There could be more than one plug, remove the plug at the lowest point.
- Remove these drain plugs to allow the water to drain out of the pumps and heater.
 - **Note:** Approximately one to two gallons will be released during this procedure. Use a wet/dry vacuum or other means to keep this from flooding the equipment compartment.
- Replace the drain plugs.
- Re-install cabinet panels and cover the spa so that no ambient moisture can enter into it. Take all precautions to shelter the spa from the weather like using a tarp.



Drain Plug

Consult your Jacuzzi dealer if you have any questions regarding winter use or winterizing.

Restarting Your Spa in Cold Weather

We recommend you consult your dealer for guidance before attempting to restart your spa under these conditions. If you want to start up your spa after it has sat empty for a time in freezing temperatures, be aware that the water remaining in certain sections of the piping may still be frozen. This situation will block water flow preventing the spa from operating properly and possibly damage the equipment.

Choosing A Location

IMPORTANT: Because of the combined weight of the spa, water and users, it is extremely important that the base upon which the spa rests be smooth, flat, level and capable of uniformly supporting this weight, without shifting or settling, for the entire time the spa is in place. Visit www.Jacuzzi.com for information. If the spa is placed on a surface which does not meet these requirements, damage to the skirt and/or the spa shell may result. Damage caused by improper support is not covered under warranty. It is the responsibility of the spa owner to assure the integrity of the support over time. We recommend a poured, reinforced concrete slab with a minimum thickness of 4 inches (10 cm). Wood decking is also acceptable provided it is constructed so that it meets the requirements outlined above.




WARNING: For spas that are to rest on balconies, roofs or other platforms not specifically tied into main structural support, consult a professional Structural Engineer with experience in this type of application.



WARNING: Proper drainage is required. The installation must prevent external water from flooding or wetting the spa equipment bay. It is your responsibility, and the responsibility of any installation contractor you hire, to make sure that all applicable codes and/or local construction requirements are met. If in doubt, refer to the building authority responsible for approving the proposed installation site.

The spa must be installed in such a manner as to provide drainage away from it. Placing the spa in a depression without provisions for proper drainage could allow rain, overflow, leaks from spa plumbing, and other casual water to flood the equipment and create a wet condition in which it would sit in. For spas which will be installed below grade or recessed into a floor or deck, install so as to permit access to the equipment, either from above or below, for servicing. Make certain that there are no obstructions which would prevent removal of all side cabinet side panels and access to the jet components, especially on the side with the equipment bay.

 **CAUTION:** If the spa is indoors or located in an enclosed area, proper ventilation should be discussed with an Engineer or authority competent enough to understand the necessary provisions needed to vent moist or heated air and air associated with chemical odors outdoors. **When the spa is in use considerable amounts of moisture will escape potentially causing mold and mildew.** This can cause health risk. Over time, this can damage certain surfaces, surroundings, and equipment.

To prevent unauthorized access and comply with local safety codes, the spa must be installed with measures that provide secure access control. This includes, but is not limited to, using a lockable spa cover, fencing, alarms, or other approved barriers. Consult with local Authorities to ensure all requirements for securing the spa are met in your installation jurisdiction.

Outdoor Location

In selecting the ideal outdoor location for your spa, we suggest that you take into consideration:

- The proximity to changing area and shelter (especially in colder weather).
- The pathway to and from your spa (this should be free of debris so that dirt and leaves are not easily tracked into the spa).
- The closeness to trees and shrubbery (remember that leaves and birds could create extra work in keeping the spa clean).
- A sheltered environment (less wind and weather exposure can result in lowered operation and maintenance costs).
- The overall enhancement of your environment. It is preferable not to place the spa under an unguttered roof overhang since run-off water will shorten the life expectancy of the spa cover.
- For spas that are to rest on balconies, roofs or other platforms not specifically tied into main structural support, consult a professional Structural Engineer with experience in this type of application.
- Should access be required for servicing, the outdoor installation should be designed to provide unrestricted access to all portions of the spa. Please take this into consideration when placing the spa in a deck or enclosed by a surrounding.
- Consider locating your spa away from any reflective surface or glass to prevent any damage to the synthetic skirt.
- Do not shim the spa. To ensure proper support the spa must sit flat on the intended foundation.

Indoor Location

For indoor installations many factors need to be considered before installing a spa indoors:



WARNING: In addition to maintenance of filters and water chemistry, proper ventilation is recommended to reduce the risk of contracting a waterborne illness (e.g. an infection, bacteria or virus) and/or respiratory ailments that could be present in the air or water. Consult a licensed architect or building contractor to determine your specific needs if installing your hot tub indoors.

- **Proper Foundation:** Consult a Structural Engineer when considering a foundation that will adequately support the spa the entire time it is in place. Proper support is critical especially if the spa is to rest on a second story or higher. For spas that are to rest on balconies, roofs or other platforms not specifically tied into the main structural support, you should consult a professional Structural Engineer with experience in this type of application.
- **Proper Drainage:** It is extremely important to have in place measures to sufficiently handle excessive water spillage. Be sure the flooring in which the spa rests on has adequate drainage and can handle the entire contents of the spa. Be sure to make provisions for ceilings and other structures that may be below the spa's installation. Areas around your spa can become wet or moist so all flooring and subsequent furniture, walls and adjacent structures should be able to withstand or resist water and moisture.
- **Proper Ventilation:** Proper ventilation should be discussed with an Engineer or authority competent enough to understand the necessary provisions needed to vent moist or heated air and air associated with chemical odors outdoors. When the spa is in use considerable amounts of moisture will escape, potentially causing mold and mildew over time which can damage certain surfaces and/or surroundings.
- **WARNING** – To reduce the risk of injury: For spas or hot tubs installed indoors, proper ventilation is required to prevent undesired humidity build-up from spa water. For additional information on ventilation and humidity guidelines, refer to the *ASHRAE Handbook, HVAC Applications, I-P Edition, Sections 4.5, 4.6, and 4.7.*
- **Sufficient Access:** In the unlikely event that you should ever need to access or gain entry to any portion of the spa for servicing, it is highly recommended that you plan your indoor installation to provide full access to the entire spa.
- **Warranty:** Damage caused by not following these guidelines or any improper installation not in accordance with local codes or authorities is not covered under the spas warranty. Please consult your local state or city building ordinances.
- **Do not shim the spa.** To ensure proper support the spa must sit flat on the intended foundation.



Message Codes



Your spa has a self-diagnostic control system. The system will automatically display the following if a problem is detected. The following is a listing of all the possible messages along with their meanings.

Always insist on genuine Jacuzzi replacement parts.

Note: If you dismiss the error, the error icon will remain on the screen as a reminder. If the error is not taken care of or fixed, the error display will reappear in 2 hours.

Message Code 1	Freeze protection active. No action required. Jet pump(s) will run until temperature normalizes.
Message Code 15	Temperature sensors are out of sync. The heater has been deactivated. Reset power to reboot the system. If the condition persists, contact your authorized dealer.
Message Code 16	Low water flow detected inside the heater. Check, clean, and replace the filters if needed.

Message Code 17	Low water flow detected inside the heater. If you have already replaced the filter, contact your authorized dealer.
Message Code 18	The heat pump is not running efficiently because of environmental conditions.
Message Code 19	Priming mode is running to clear any air trapped in the plumbing lines. Wait until the priming mode completes its cycle.
Message Code 20	Clock error detected. Reset power to reboot the system. If the condition persists, contact your authorized dealer.
Message Code 21	Factory settings restored.
Message Code 22	Program memory failure. Please contact your authorized dealer.
Message Code 23	Configuration error. Please contact your authorized dealer.
Message Code 26	Sensor error. Heater off. Power cycle to reset. If it continues, contact your authorized dealer.
Message Code 27	Low water flow detected. Check and clean filters as needed.
Message Code 28	Low water flow detected inside the heater. If you have already replaced the filter, contact your authorized dealer.
Message Code 29	DO NOT ENTER THE SPA! The water is too hot. Spa operation is paused until the water cools.  WARNING: RISK OF HYPERTHERMIA (OVER-HEATING) CAUSING SEVERE INJURY, BURNS, OR WELTS.
Message Code 30	DO NOT ENTER THE SPA! The water is too hot. Spa operation is paused until the water cools.  WARNING: RISK OF HYPERTHERMIA (OVER-HEATING) CAUSING SEVERE INJURY, BURNS, OR WELTS.
Message Code 31	Heater outlet sensor fault detected. Contact your authorized dealer.
Message Code 32	Heater outlet sensor fault detected. Contact your authorized dealer.
Message Code 34	One of the pumps is running continuously. Contact your authorized dealer.
Message Code 35	DO NOT ENTER THE SPA! Water too hot because one of the pumps is running continuously. Contact your authorized dealer.
Message Code 36	The internal GFCI test has failed. Contact your authorized dealer.
Message Code 40	Set the time.
Message Code 44	Error Jumper 29 detected. Contact your authorized dealer.
Message Code 65	Lighting communication error. Contact your authorized dealer.
Message Code 67	Lighting circuit detected amperage out of specified range. Reset power to reboot the system. If condition persists, contact your authorized dealer.
Message Code 68	The Heat Pump has stopped communicating. Contact your authorized dealer.
Message Code 69	The Heat Pump reported an internal fault. Contact your authorized dealer.
Message Code 70	The Heat Pump is defrosting. This is normal operation.
Message Code 71	The Heat Pump did not turn off. Reset the power to the spa. If message reappears, contact your authorized dealer.

Message Code 72	The Heat Pump did not turn on. Reset the power to the spa. If message reappears, contact your authorized dealer.
Message Code 73	The Heat Pump flow error. Contact your authorized dealer.
Message Code 74	The Heat Pump turned off. Reset the power of the spa. If message reappears, contact your authorized dealer.
Message Code 75	The Heat Pump is not running efficiently because of environmental conditions.
Message Code 76	The Heat Pump compressor is off. Reset the power of the spa. If message reappears, contact your authorized dealer.
Message Code 77	The Heat Pump has reset.
Message Code 78	The Heat Pump is too hot. It will automatically reset. If message reappears, contact your authorized dealer.
Message Code 79	The Bluewave® has stopped communicating with the spa pack.
Message Code 80	Unauthorized heater detected. Spa operation is now limited. Please contact your authorized dealer.
Message Code 81	True sanitizer fault.
Message Code 254	System communication lost. Contact your authorized dealer.
True Air filter reminder	It's time to replace your air filter cartridge. This message will appear when the Air Filter reminder time has expired. The Air Filter must be replaced.
Filter 1 Reminder	It's time to clean your filtration system. This message will appear when the filter reminder time has expired. Remove the Proclear filters and ProCatch Debris basket for cleaning or replacement.
Filter 2 Reminder	This message will appear when the filter reminder time has expired. The ProClarity Polishing filter must be replaced.
Water Refresh Reminder	This message will appear when the Water Refresh timer has expired. The water needs to be drained and refilled with fresh water.
Ozone Replacement Reminder	This message will appear when the Ozone reminder time has expired. The Ozone must be replaced.
Extended Temperature Activated	<p>The spa is set to go up to 104°F (40°C), but it can be set to reach 106°F (41°C). To access the extended temperature, you need to press and hold your finger over the temperature reading for about 5 seconds. The grayed out + button will change state to indicate the system is ready. Tap + to raise the temperature up to 106°F (41°C). The images to the right are indicators when this feature is active.</p>   <p>⚠️ WARNING: RISK OF HYPERTHERMIA (OVER-HEATING) CAUSING SEVERE INJURY, BURNS, WELTS OR DEATH! Water temperature in excess of 104°F (40°C) may be injurious to your health.</p>

Troubleshooting Procedures

NONE OF THE COMPONENTS OPERATE

1. If there are letters or symbols displayed on the screen, refer to the previous Section to determine the meaning and action required.
2. If nothing appears on the screen:
 - A. Check the household circuit breaker. If tripped, reset the breaker. If it continues to trip, contact your dealer.

PUMP DOES NOT OPERATE: Activate the pump:

1. If no sound is detected or if a “buzzing” sound is detected, turn off power to the spa and contact your dealer or service center.
2. If motor operates but no water flows to jets:
 - A. Pump may not be properly primed. Make sure not to bypass the Priming Mode feature.
 - B. Contact dealer or authorized service center.

POOR JET ACTION

1. Make certain the jets pump is turned on.
2. Check position of massage selectors.
3. Open air control for selected jet system.
4. Check for adequate water level.
5. Make sure the Jet face(s) are turned to the open position.
6. Check for dirty filter (page 23).

WATER IS TOO HOT

1. Reduce thermostat setting.
2. Switch spa to “Economy” mode to turn heater on only during pre-programmed time (page 15).
3. Make sure the pumps are turned off and not constantly running.

NO HEAT

1. Check thermostat setting.
2. Keep the cover in place while heating.
3. If heating indicator is displayed, but no temperature increase is experienced after a reasonable period of time, contact your dealer or authorized service center.

FILTER/CIRCULATION PUMP OFF

1. Verify circulation pump is programmed to run (page 15).
2. Make sure there are no errors preventing the pump from turning on.

Jacuzzi builds the best spas in the industry. Nonetheless, we are always striving to improve the quality and features of our products. Your input as a Jacuzzi spa owner is a cherished part of this process. If you have any comments or suggestions, or if you wish to be informed on any new products for your spa, please write to us. Please see company information at the end of the manual.

CONGRATULATIONS and welcome to the happiest and most relaxed family in the world!

FOR ELECTRICIANS

General Electrical Safety Instructions

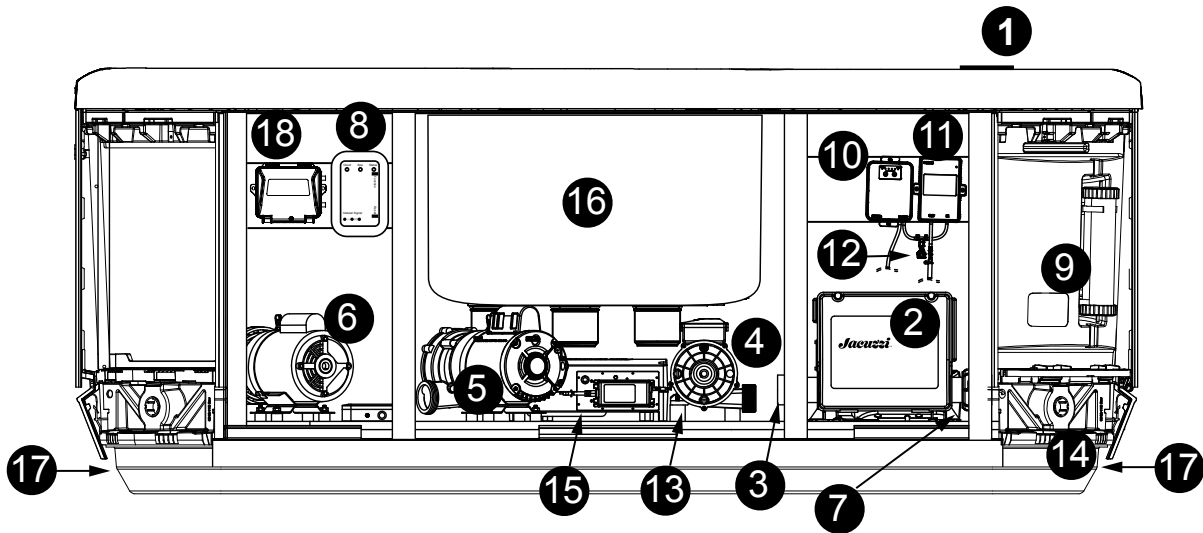
This new Jacuzzi hot tub is equipped with a “state-of-the-art” equipment system. It contains the most advanced safety and self-protective equipment in the industry. Nonetheless, this spa must be installed properly to ensure dependable usage. Please contact the dealer or local building department should you have any questions regarding the installation.

Proper grounding is extremely important. Jacuzzi hot tubs are equipped with a current collector system. A pressure wire connector is provided on the surface of the control box, located outside the equipment door (page 35) to permit connection of a bonding wire between this point and any ground metal equipment, metal water pipe or conduit within 5 feet (1.5m) of the spa, or copper clad grounding rod buried within 5 feet (1.5m) of the hot tub. Bonding wire must be at least No. 8 AWG (8.4 mm²) solid copper wire. This is a most important safety assurance feature. Before installing this spa, check with the local building department to ensure installation conforms to local building codes.

IMPORTANT NOTE: All Jacuzzi® hot tubs are specifically designed for portability and movement. Engineered to be freestanding, portable and accessible with no fixed position. These products comply with all relevant directives and standards for portable spas. These units should be properly installed by a certified installing electrician to the recommended service box (GFCI/RCD) as per local regulations.

Equipment Area

Note: Equipment location and quantity (such as pumps, True Water® system, stereo, drain, heater etc.) varies by model.



- | | |
|----------------------------|-----------------------------------|
| 1. ProTouch™ Control Panel | 10. True Water® Air Pump |
| 2. Controller | 11. True Water® Ozone Unit |
| 3. Heater | 12. True Water® Pressure Sensor |
| 4. Circulation Pump | 13. True Water® Nano Bubbles Unit |
| 5. Jets Pump | 14. Drain |
| 6. Jets Pump | 15. BLUEWAVE® 2.0 Wireless Stereo |
| 7. Jets Pump | 16. Filter Housing |
| 8. SmartTub® System | 17. Power Supply Entrance(s) |
| 9. True Water® Air Filter | 18. Light DCU |

Power Requirements

Jacuzzi® spas are designed to provide optimum performance and flexibility of use when connected to their maximum electrical service. We recommend using a Square D breaker. The electrical wiring of this spa must meet the requirements of the National Electrical Code/USA (NEC) and any applicable state or local codes.

North American Models (60 Hz) 2-Pump System			
Voltage:	240 VAC	240 VAC	240 VAC
Amperage	32A	40A	48A
Frequency:	60 Hz	60 Hz	60 Hz
Number of Wires:	3	3	3
Circuit Breaker (2-Pole)	40A*	50A**	60A***
<p>* In the 40A configuration, the heater will not operate with Hydromassage therapy level 2 and level 3.</p> <p>** In the 50A configuration, the heater will not operate with Hydromassage therapy level 3. This is the factory setting.</p> <p>*** In the 60A configuration, the heater will operate with Hydromassage therapy level 1, level 2, and level 3.</p>			

North American Models (60 Hz) 3-Pump System		
Voltage:	240 VAC	240 VAC
Amperage	35A	48A
Frequency:	60 Hz	60 Hz
Number of Wires:	3	3
Circuit Breaker (2-Pole)	50A*	60A**
<p>* In the 50A configuration, the heater will operate with Hydromassage therapy level 1 but will not operate with Hydromassage therapy level 2 and level 3. This is the factory setting.</p> <p>** In the 60A configuration, the heater will operate with Hydromassage therapy level 1 and level 2 but will not operate with Hydromassage therapy level 3.</p>		

Electrical Wiring Instructions

IMPORTANT NOTICE: The electrical wiring of this spa must meet the requirements of the National Electrical Code/USA (NEC) and/or any applicable state or local codes. The electrical circuit must be installed by a qualified electrician and approved by a local building/electrical inspection authority.


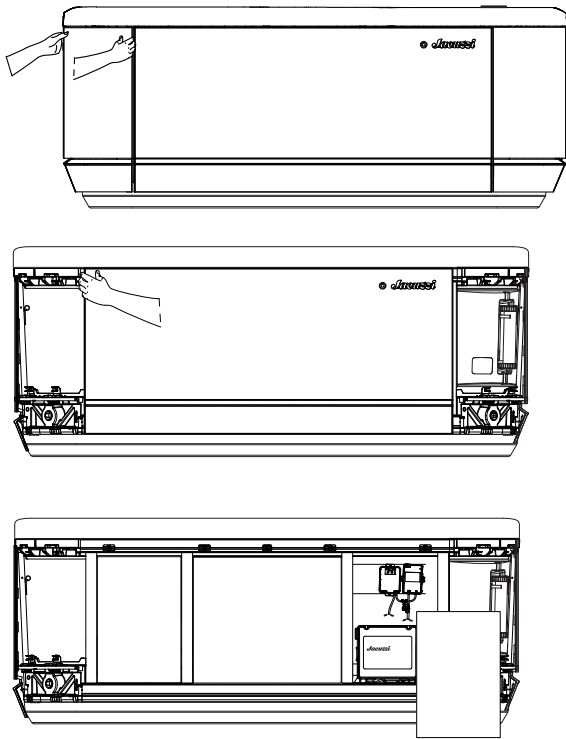
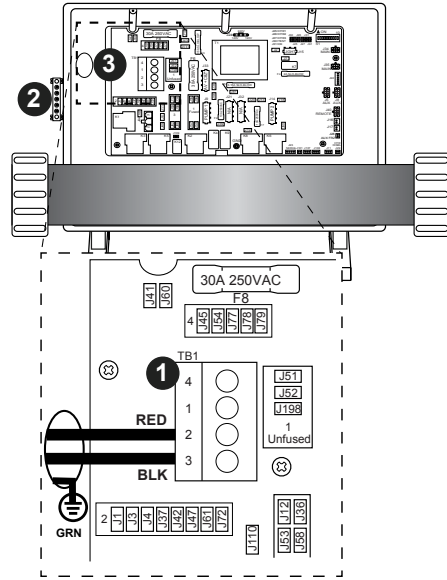
1.  **DANGER: TO DECREASE THE RISK OF SHOCK, PRODUCT DAMAGE OR ELECTRICAL FIRE!** This spa must be permanently connected (hard-wired) to the power supply. **No plug-in connections or extension cords are to be used in conjunction with the operation of this spa.** Supplying power to the spa, which is not in accordance with these instructions, will void both the independent testing agency listing and the manufacturer's warranty.
2. The power supplied to this spa must be a dedicated circuit with no other appliances or lights sharing the power provided by the circuit.
3. To determine the current, voltage and wire size required, refer to Section "Power Requirements" (page 33).
 - Wire size must be appropriate per NEC/USA and/or local codes.
 - The spa controller's terminal block will accept a maximum wire size of 6 AWG (10 mm²).
4. The electrical supply for this product must include a suitably rated switch or circuit breaker to open all ungrounded supply conductors to comply with Article 422.20 of the National Electrical Code/USA, ANSI/NFPA 70. The disconnecting means must be readily accessible to the spa's occupant but installed at least 5 feet (1.5m) from spa water.
5. The electrical circuit supplied for the spa must include a suitable ground fault circuit interrupter (GFCI) as required by NEC/USA Article 680.42.
6. To gain access to the spa's power terminal block:
 - Grab one of the corner panels from both sides at the top. Then gently pull the panel forward to unsnap it from the holding clamps, Figure A. Place the panel in a safe location to prevent from damaging it. Repeat the steps to remove the other corner panel.
 - Grab the top of the front panel, start on one side of the hot tub and work your way down the panel. Gently pull the panel forward to unsnap it from the holding clamps. Slightly tilt the panel forward and lift up to remove, Figure A. Take care when removing the panel to avoid damaging the wires of the motion sensor. Disconnect the motion sensor by pulling it out of the housing. Place the panel in a safe location to prevent from damaging it. Place the panel in a safe location.
 - Remove the foam insulation panels to access the equipment. Place the insulation panels in a safe location.
7. Select the power supply inlet you want to use (page 32). Make sure to install a 3/4" electrical fitting and conduit through the large opening provided in the side of the control box so you can feed the cable through to the terminal block.
8. Remove the controller box door to access the terminal block, Figure B. Connect wires, color to color, on terminal block TB1, Figure C. **TIGHTEN SECURELY!** All wires must be hooked up securely or damage could result.
9. Once the connections have been made and tested. Reinstall the controller box door.
10. Reinstall the foam insulation panels, Figure C. Then reinstall the front panel, Figure C. Slide the bottom hooks into the frame rail. Align the center connector located in the middle of the panel with the center metal clamp on the frame. Push to snap the connector in place. Work your way to the left and right of the panel, pressing the remaining connectors into their clamps. Lastly, take the corner panel and align the connector at the bottom with the clamps and press into place, Figure C. Do the same for the top of the panel.

Figure A

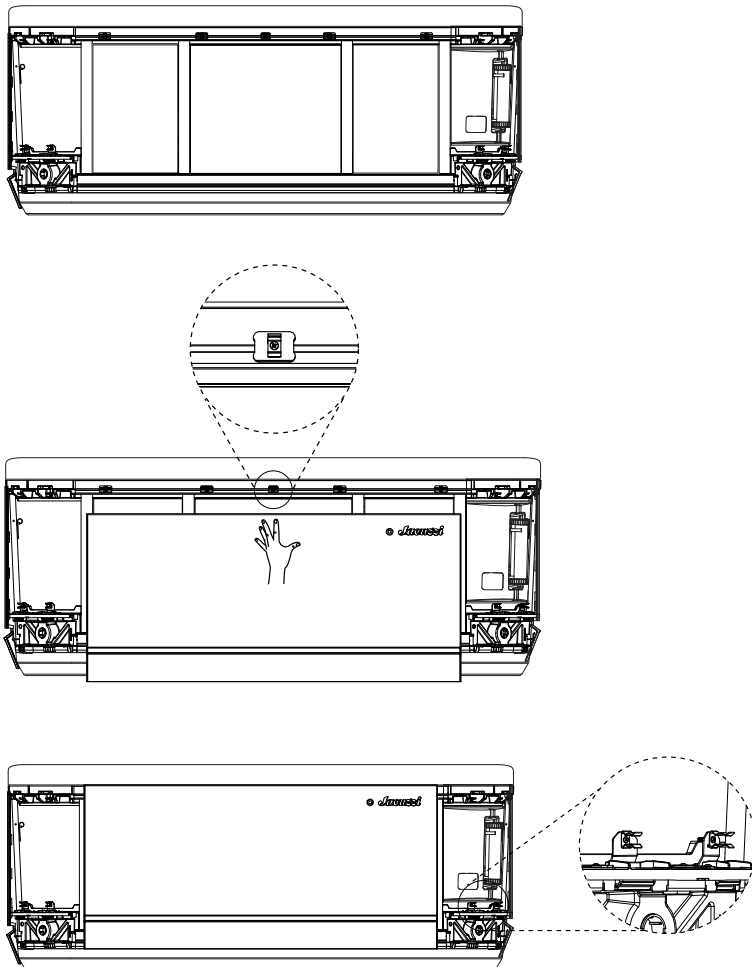


**Figure B
Control Box Connection**



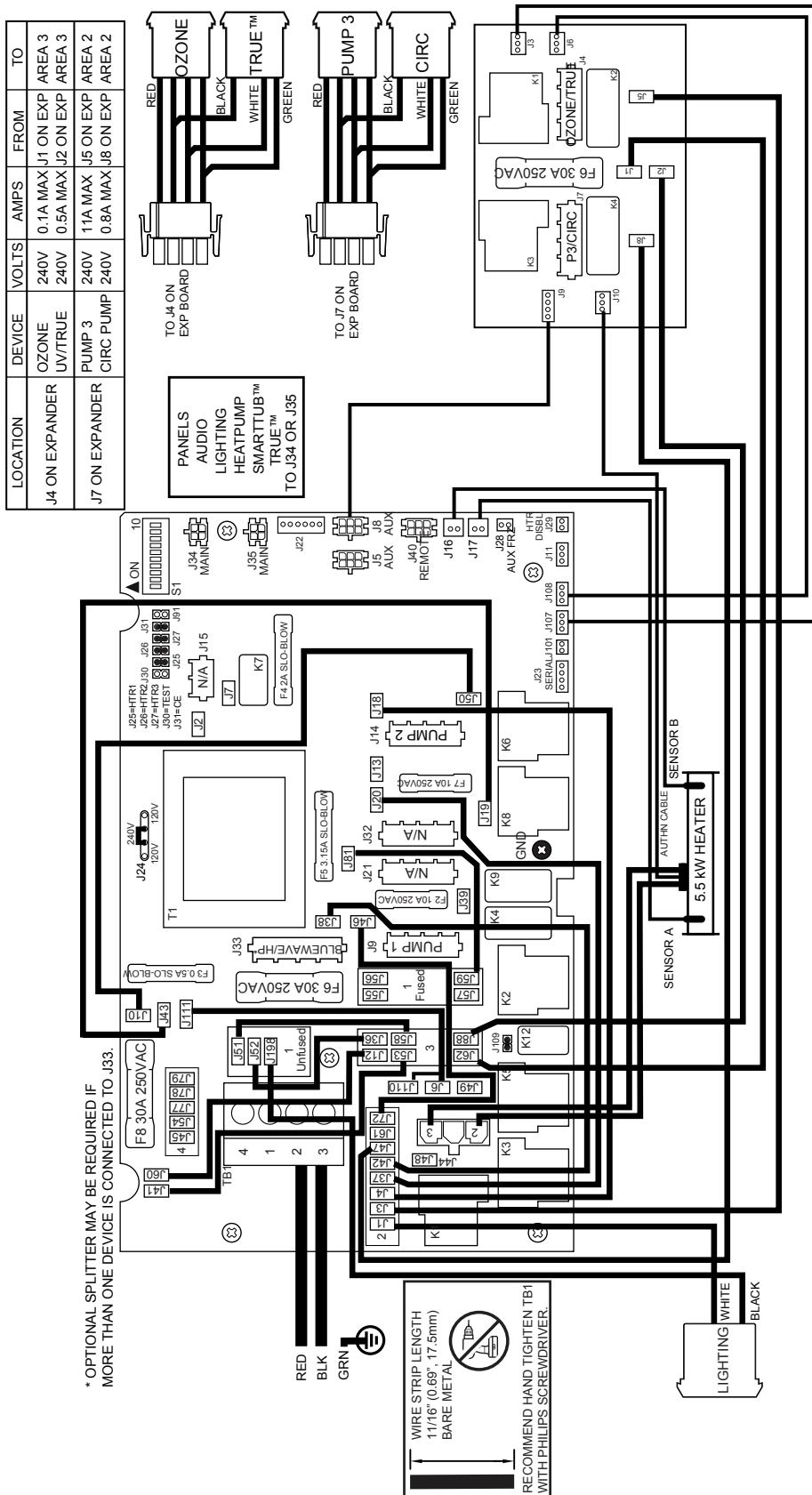
1. Main Terminal Block
2. Bonding Lug/Grounding Terminal
3. Power wires Entrance (Electrical fitting and conduit must be installed)

Figure C



Circuit Board Wiring Diagrams

- 2-Pump Domestic 60Hz Wiring Diagram
- 3-Pump Domestic 60Hz Wiring Diagram



* OPTIONAL SPLITTER MAY BE REQUIRED IF MORE THAN ONE DEVICE IS CONNECTED TO J33.

RED
BLK
GRN

WIRE STRIP LENGTH
1 1/16" (0.69" - 17.5mm)
BARE METAL

RECOMMEND HAND TIGHTEN TB1 WITH PHILIPS SCREWDRIVER.

⚠ DANGER
RISK OF SHOCK OR ELECTROCUTION!

Turn power off before servicing. This task should only be performed by a qualified technician.

Dip Switch Settings

SWITCHBANK S1 OFF

SWITCHBANK S1 ON

TEST MODE OFF	◀ 1	TEST MODE ON
MUST BE OFF	◀ 2	N/A
SEE TABLE	◀ 3	SEE TABLE
SEE TABLE	4 ▶	SEE TABLE
MUST BE OFF	◀ 5	N/A
STORE SETTINGS**	◀ 6	MEMORY RESET**
MUST BE OFF	◀ 7	N/A
UNASSIGNED	◀ 8	N/A
UNASSIGNED	◀ 9	N/A
DEMO MODE OFF	◀ 10	DEMO MODE ON

** SWITCH #6 SHOULD BE SET TO OFF UPON FINAL INSTALLATION.

BREAKER	DIP SWITCH NUMBER									
	1	2	3	4	5	6	7	8	9	10
40A**	OFF	OFF	ON	OFF	OFF	OFF	OFF	OFF	OFF	OFF
50A*	OFF	OFF	OFF	ON	OFF	OFF	OFF	OFF	OFF	OFF
60A	OFF	OFF	ON	ON	OFF	OFF	OFF	OFF	OFF	OFF
*50A is the factory default setting										
** Do not use on a 3-pump system										

Jacuzzi® Hot Tub FAQ

General Questions

- Q: How often should I use my Jacuzzi® hot tub?
 - A: You can enjoy your Jacuzzi® daily! Most owners soak 3–5 times a week for 15–30 minutes to relax muscles and reduce stress.
- Q: What's the ideal temperature for a Jacuzzi® hot tub?
 - A: Jacuzzi® recommends keeping the water between 100°F and 104°F (37°C–40°C). For children or extended soaks, set it closer to 98°F.
- Q: How long does it take for a Jacuzzi® hot tub to heat up?
 - A: From cold water, this will take approximately 12-24 hours and will vary depending on the starting water temperature, ambient air temperature and hot tub size.
- Q: Can I use my Jacuzzi® hot tub in winter?
 - A: Absolutely. All Jacuzzi® hot tubs are insulated and engineered for year-round use, even in freezing temperatures.

Water Care & True Water® System

- Q: How often should I change the water?
 - A: Jacuzzi® recommends draining and refilling your spa every 3 months, depending on usage and water quality.
- Q: What is the True Water® System?
 - A: True Water® system that brings a world-leading clean¹ water technology system to home spas. True Water makes spa water fresh and clear without all the harsh chemicals. Trillions of oxygen-filled nanobubbles continuously scrub away contaminants² to deliver clear, sparkling water that is 99.9999% chlorine-free. That's even less than drinking water.³ You'll see, feel, and smell the difference. Scan to learn more about how True Water is revolutionizing water care.
 - ¹Clean is defined as the removal of microscopic dirt and debris (down to 3-micron level, varies by model) from the water. ²Contaminants include dirt and grit. ³Spa water is meant for soaking, not for sipping.
 - The Jacuzzi True Water® care system works along with the Frog® @ease® SmartChlor and Frog @ease Mineral to lower the use of chemicals and maintain your hot tub water.
- Q: Do I still need sanitizer with True Water® System?
 - A: Yes. You should still use chlorine or bromine to maintain proper sanitizer levels for complete protection. See ideal water balance levels.
- Q: How often should I test the water?
 - A: Test 2–3 times a week using Jacuzzi® test strips to ensure sanitizer, pH, and alkalinity are balanced.
- Q: What are the ideal water balance levels?
 - A: Chlorine: 0.5 ppm (1.0 ppm outside US)
 - Bromine: 2.0 ppm
 - pH: 7.2–7.8
 - Total Alkalinity: 80–120 ppm
 - Calcium Hardness: 200–400 ppm

Cleaning & Maintenance

- Q: How often should I clean my filters?
 - A: Rinse filters weekly, deep clean monthly with Jacuzzi® filter cleaner, and replace them every 12–18 months.

- Q: What's the best way to clean the Jacuzzi® shell?
 - A: Use a Jacuzzi®-approved spa cleaner and a soft sponge or cloth when the tub is drained. Avoid household cleaners or abrasives.
- Q: Should I leave my Jacuzzi® hot tub running all the time?
 - A: Yes — Jacuzzi® spas are energy-efficient and designed to stay on. Maintaining a constant temperature saves energy versus reheating from cold.

SmartTub® System

- Q: What is the SmartTub® system?
 - A: SmartTub® is a Wi-Fi-enabled monitoring and control system that lets you adjust temperature, set schedules, and track energy use from your smartphone.
- Q: How do I connect my Jacuzzi® to the SmartTub® app?
 - A: Download the Jacuzzi® SmartTub® app from the App Store or Google Play, follow the set-up instructions and link your spa using the activation code on your control panel.

Safety & Usage

- Q: Can children use a Jacuzzi® hot tub?
 - A: Yes, with supervision. Keep temperature below 100°F and limit soak time to 5–10 minutes.
- Q: Is it safe to use my Jacuzzi® hot tub during pregnancy?
 - A: Consult your healthcare provider before use. Prolonged exposure to high temperatures is not recommended.
- Q: Should I shower before using my Jacuzzi® hot tub?
 - A: Yes — rinsing off removes oils, lotions, and detergents that affect water clarity and sanitizer efficiency.

Cover & Accessories




- Q: How do I care for my Jacuzzi® hot tub cover?
 - A: Clean monthly with mild soap and water, then apply a UV vinyl protectant to prevent fading and cracking.
- Q: What accessories are available for my Jacuzzi®?
 - A: Popular add-ons include Jacuzzi® steps, cover lifters, SmartTub® upgrades, headrests, aromatherapy products, and spa pillows.

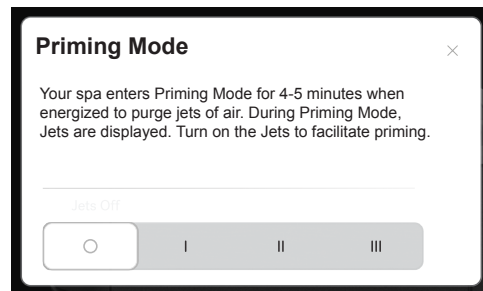
Detailed Spa Operations and Programming

Start-up

When power is activated, the control panel will display several initializing menus.

When the Priming Mode Menu is displayed it is recommended that you activate all the jets pumps to clear the plumbing lines.

- Press , , and . Allow for the Priming Mode to run for it's 4 to 5 minutes cycle.




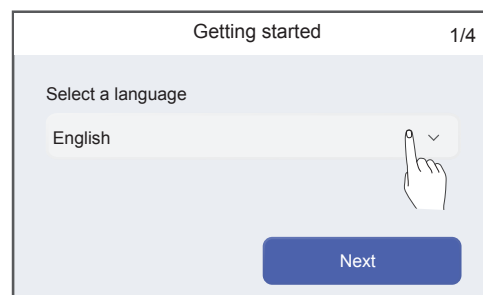
After the cycle is done, the initializing menus will continue to reach the Getting Started Menus.

Initial Start-up Menus

At the very first activation, some of the settings need to be programmed.

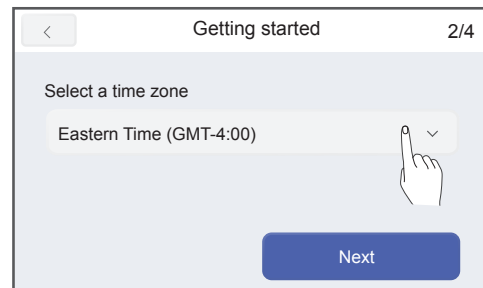
Language

- Default is English
- Choose from 10 Languages
 - English
 - French
 - Spanish
 - German
 - Norwegian
 - Italian
 - Polish
 - Swedish
 - Czech
 - Finnish
- Select  to continue.

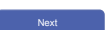


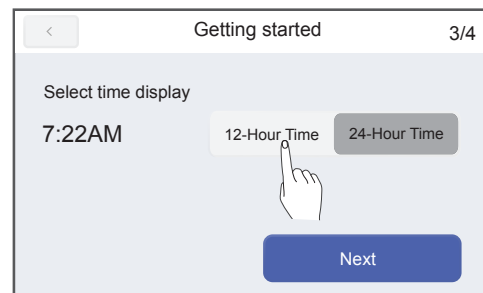
Time Zone

- Default is Pacific Standard Time
- Choose from 25 Time Zones





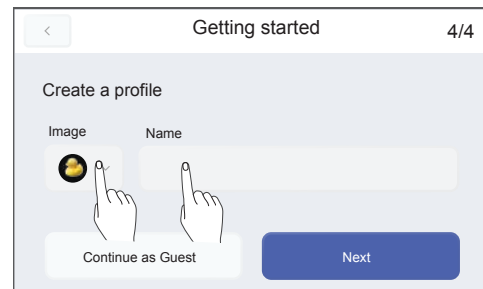
Time Display

- Default is 12-Hour Time. Displayed as 7:22^A or 7:22^P.
- Another option is 24-Hour Time. Displayed as 13:22.
- Select  to continue.



Create a profile

- Default is a Guest profile. You can select that option and continue as a guest.
- You can enter a profile, see page 41 for instructions.
- Choose an image, . There are ten image selections.
- Type in the profile name.
- Select  to continue.



Quick Start Video


- Scan the QR code to watch a video on how to use your spa.
- Select to pair your phone to the spa.



Pairing your phone (SmartTub®)

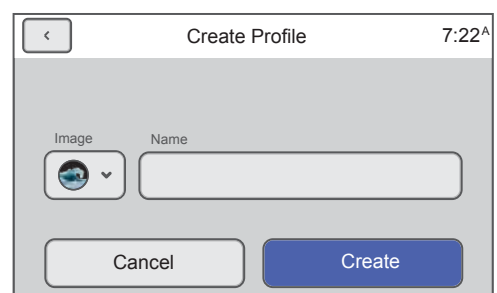
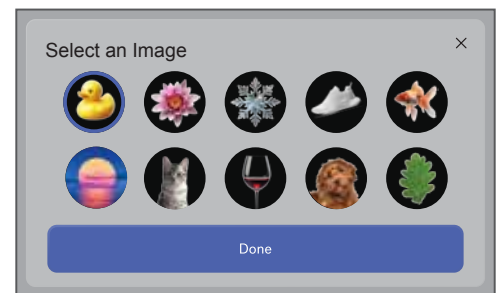
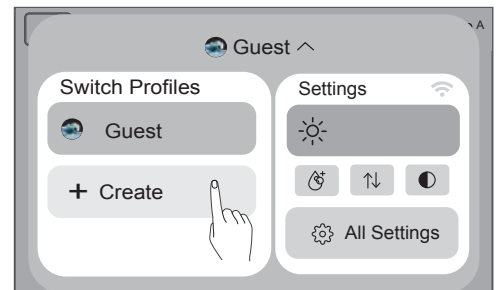
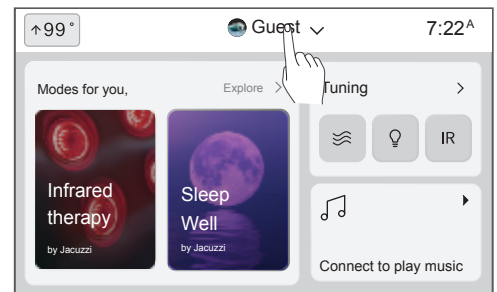
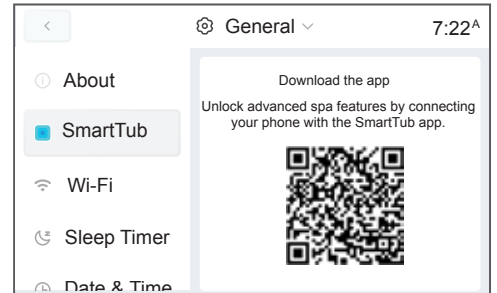
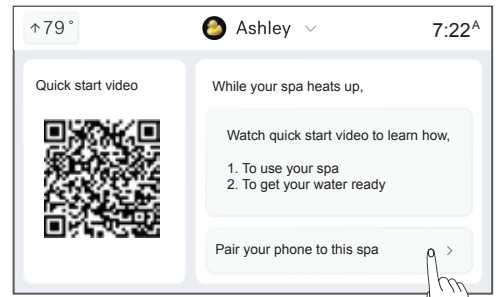
- Scan the QR code to download the SmartTub app to connect your phone.
- Follow the instructions provided.


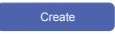
Create a profile

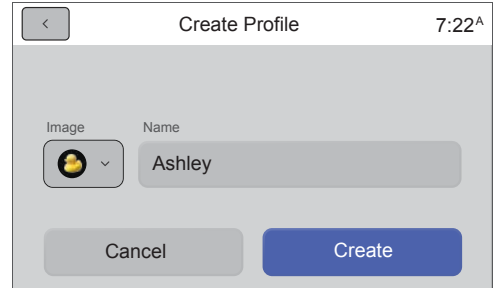
- Select the Guest tab to drop-down the menu.

- Select  to create a new profile.
 - There are a total of 5 profiles allowed. You can create up to four new profiles, plus the guest.






- Select  to select your profile image. Press  when selected.

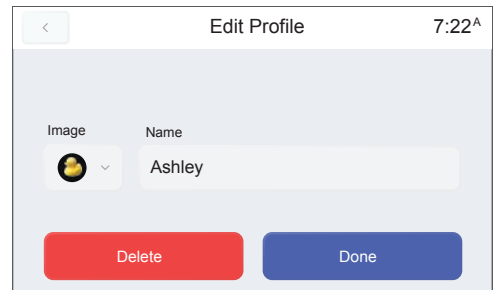
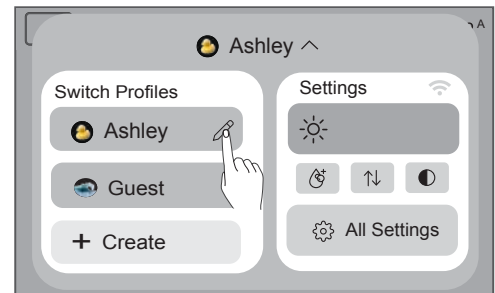


- Select the Name tab to enter your profile name.
 - Use the keyboard to type in the profile name.
 - Press  when done.
- Select  to save the new profile.

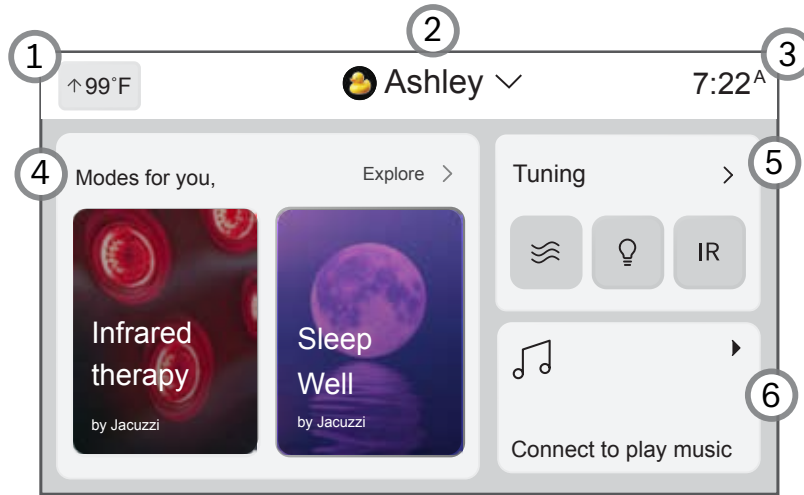


Edit/Delete/Switch profiles

- Select the profile name to open the drop down-menu.
- Here you can switch, edit or delete profiles.
- To switch profile, just press the name tab for it.
- To edit a profile, press the edit icon .
- To delete a profile, press the edit icon  and press .
- To delete a profile, press the edit icon  and press .

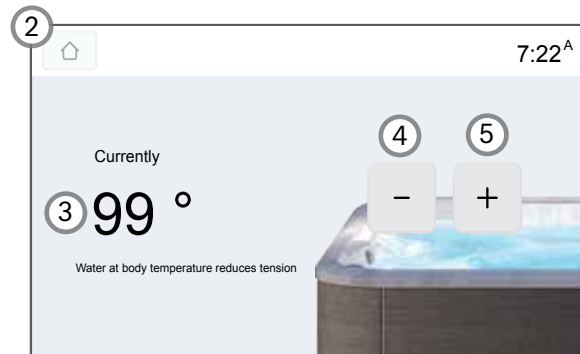
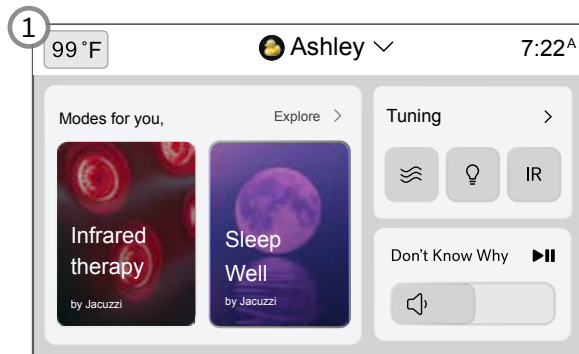


Home Menu



1. **Temperature:** Displays the current water temperature and heating status. Press to enter the Heating Menu.
2. **Profile:** Displays the current active profile. Also provides access to the Setting Menus.
3. **Time:** Displays the current time.
4. **Modes Widget:** Provides access to the preset or saved modes.
5. **Tuning Widget:** Provides quick access to activate the jets, lights, and IR therapy. You can also enter the Tuning Menu for additional functions.
6. **Sound Widget:** Provides quick access to play music. You can also enter the Music Menu for additional functions. Bluetooth device must be connected.

Heating

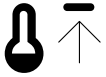


1. **Temperature:** Displays the current water temperature. Press to enter the Heating Menu.
2. **Home button:** Press to exit the menu and return to the Home Menu.
3. **Set Temperature:** Displays the set temperature.
4. **Decrease Temperature button:** Press to lower the set temperature to a minimum of 65 °F (18.33 °C).
5. **Increase Temperature button:** Press to raise the set temperature to a maximum of 104 °F (40 °C).
 - When the temperature is changed, a message below the temperature will provide an approximate time frame that it will take to reach the new setting.
 - When the temperature is being modified, this icon (⊖) will display.
 - When the temperature is being modified, this icon (⊕) will display.

Extended Temperature Feature

The temperature range for the spa is 65-104 °F (18.33-40 °C). To activate the extended temperature feature that allows the spa to reach 106 °F (41 °C) follow the instructions below.

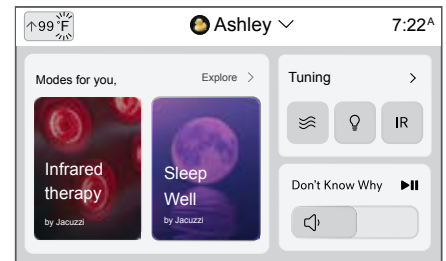
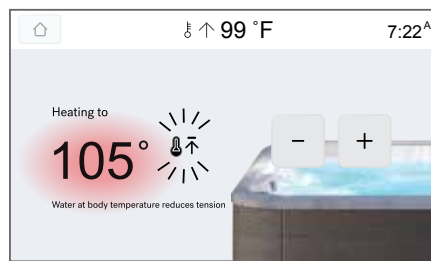
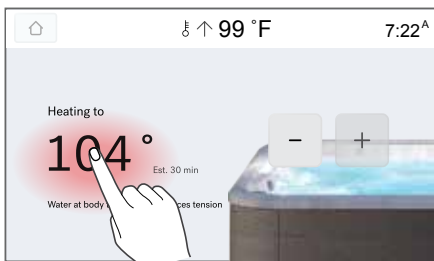
- Press and hold the temperature reading for about 5 seconds. This will change the + button from grayed out to active.
- Press + button to raise the temperature up to 106 °F (41 °C).



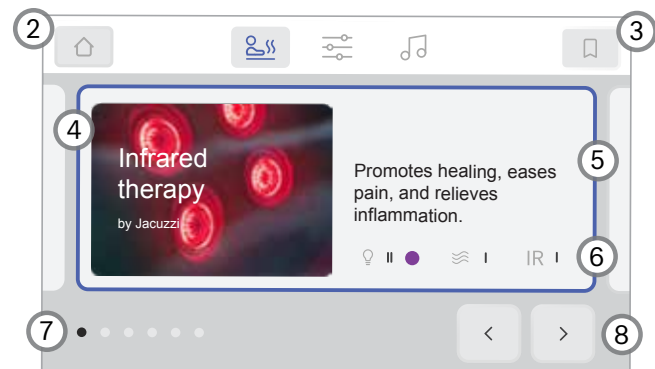
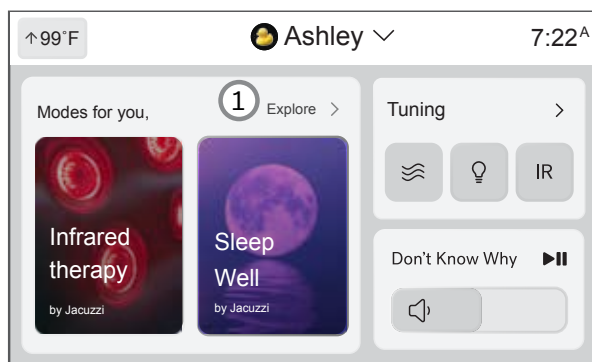
This icon will appear when adjusting the temperature to 106 °F (41 °C) to indicate that the extended temperature feature is active.



This icon appears on the Home menu to indicate that the extended temperature feature is active.



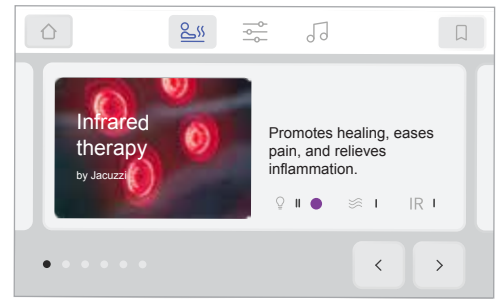
Modes



1. **Explore:** Press to enter the Modes Menu.
2. **Home (Back):** Press to exit the Modes Menu and return to the Home Menu.
3. **Bookmark:** Press to save a new mode.
4. **Mode Image:** Displays the mode image by name and creator.
Note: when a mode is active a blue rectangle will appear around it.
5. **Mode Descriptions:** (For Preset Modes) Provides a brief description of the modes affects.
6. **Mode Settings:** Displays the preset functions for the mode, such as lighting effects, pumps active, and if the IR therapy is on or off.
7. **Mode Indicator:** Displays which of the preset modes is active.
8. **Scroll buttons:** Press to scroll through the modes.

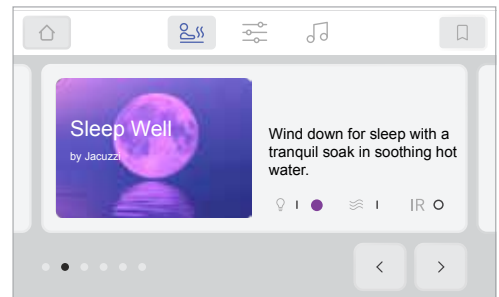
Infrared therapy Mode

- Lighting:
 - Intensity level is set to ambient.
 - Color is purple.
 - Color blending is off.
- Hydromassage:
 - Setting is set to gentle.
 - 2-Pump System: Pump 1 on low; Pump 2 on low.
 - 3-Pump System: Pump 1 on low; Pump 2 on low, Pump 3 is off.
- Infrared therapy is on. Has a 20-minute timeout.



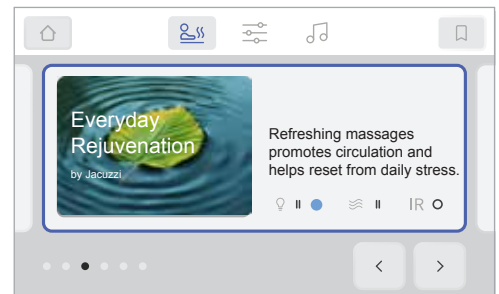
Sleep Well Mode

- Lighting:
 - Intensity level is set to low.
 - Color is purple.
 - Color blending is off.
- Hydromassage:
 - Setting is set to gentle.
 - 2-Pump System: Pump 1 on low; Pump 2 on low.
 - 3-Pump System: Pump 1 on low; Pump 2 on low, Pump 3 is off.
- Infrared therapy is off.



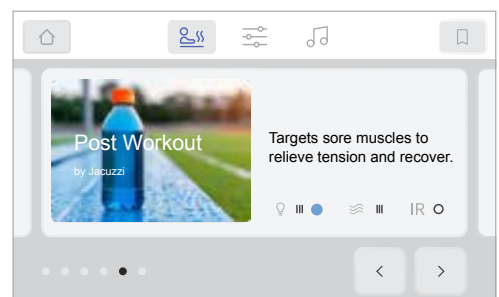
Rejuvenation Mode

- Lighting:
 - Intensity level is set to ambient.
 - Color is blue.
 - Color blending is off.
- Hydromassage:
 - Setting is set to refresh.
 - 2-Pump System: Pump 1 on low; Pump 2 on high.
 - 3-Pump System: Pump 1 on high; Pump 2 on high, Pump 3 is off.
- Infrared therapy is off.



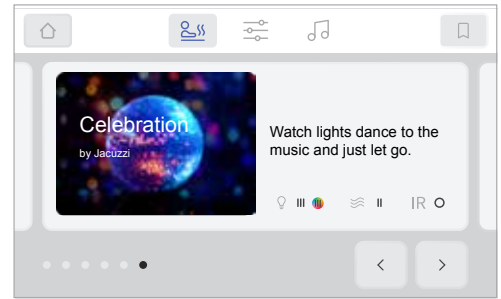
Post Workout Mode

- Lighting:
 - Intensity level is set to bright.
 - Color is blue.
 - Color blending is off.
- Hydromassage:
 - Setting is set to intense.
 - 2-Pump System: Pump 1 on high; Pump 2 on high.
 - 3-Pump System: Pump 1 on high; Pump 2 on high, Pump 3 is high.
- Infrared therapy is off.




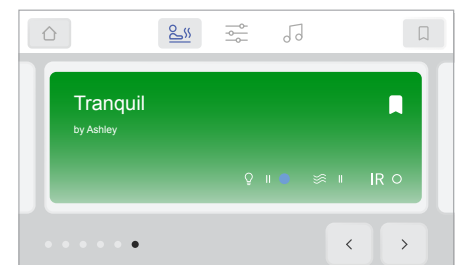
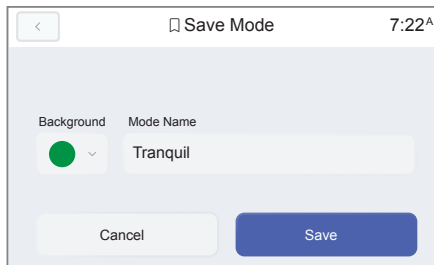
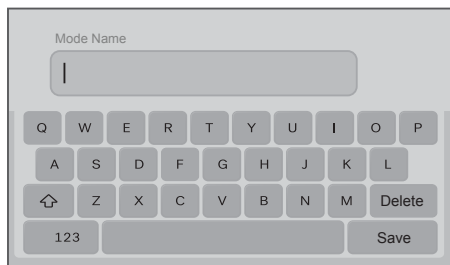
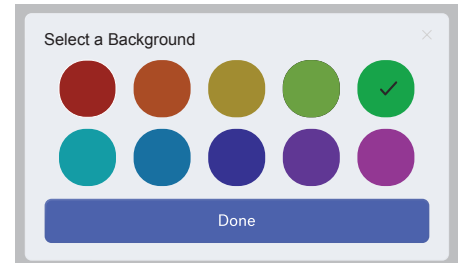
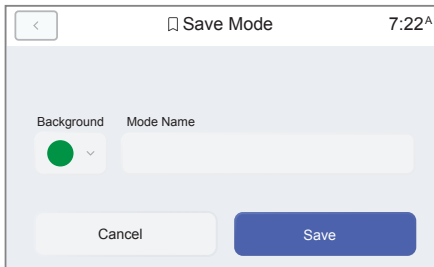
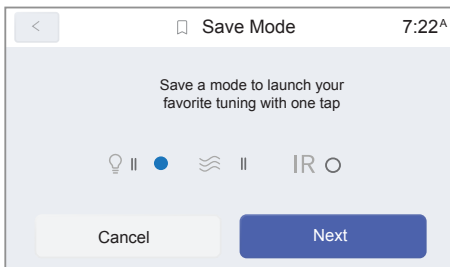
Celebration Mode

- Lighting:
 - Intensity level is set to bright.
 - Color is multi-color.
 - Color blending is set to high.
- Hydromassage:
 - Setting is set to refresh.
 - 2-Pump System: Pump 1 on low; Pump 2 on high.
 - 3-Pump System: Pump 1 on high; Pump 2 on high, Pump 3 is off.
- Infrared therapy is off.

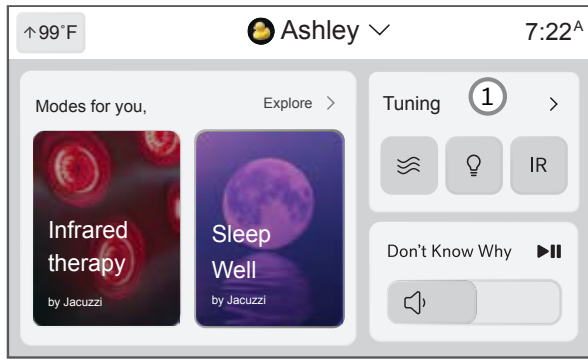


Saving a New Mode

- Go to the Tuning Menu, page 47.
- Set the light intensity, color, and jets pumps to levels that appeal to you.
- Press the Bookmark () button.
- Press the Next button.
- Press the Background button to select a color for the new mode. Once selected press done.
- Press the Mode Name tab to enter Name for the new mode. Type in the title and press the Save button. This will exit the keyboard menu.
- Press the Save button to save your new mode.






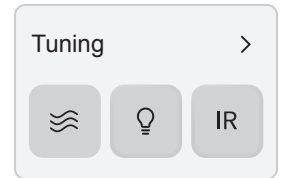
Tuning






1. Tuning quick access: Quick access to turn on or off the Jets Pumps, Lighting, or Infrared therapy.
2. Home (Back): Press to exit the Tuning Menu and return to the Home Menu.
3. Modes: Press to enter the Modes Menu.
4. Tuning: Displays that Tuning Menu is active.
5. Sound: Press to enter the Music Menu.
6. Bookmark: Press to save a new mode.
7. Infrared therapy (IR): Press the IR button to activate the Infrared therapy for 20 minutes.
8. Information buttons: Press one of the four buttons to display its function.
9. Light intensity control: Press to activate one of the intensity modes.
10. Lighting options: Press to enter the Lighting Options Menu.
11. Hydromassage control: Press to activate the Jets Pumps.

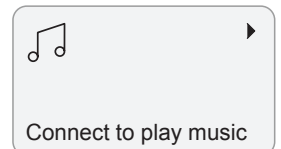
Tuning Quick Access

- Press () to activate the Hydromassage at the gentle level. For additional control, enter the Tuning Menu.
- Press () to activate the lighting at the low level in the previously used color. For additional control, enter the Tuning Menu.
- Press () to activate the Infrared therapy for 20 minutes.

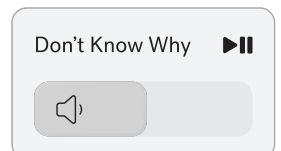


Sound

- Press the arrow to enter the Music Menu.
- Pair your Bluetooth device to the BlueWave sound system. If a pairing code is needed use pin 0000. The BT icon will appear on the Menu.
- Once a device is connected you can control the volume, play/pause, fast forward or rewind functions. Press () to enter the Audio Settings Menu.
- Press () to switch users and pair to a different Bluetooth device.
- Press the BT icon to switch to an Auxiliary device ().

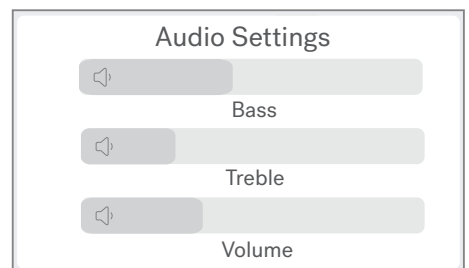
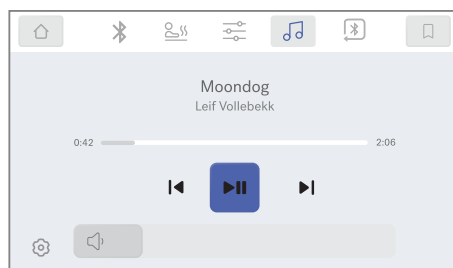
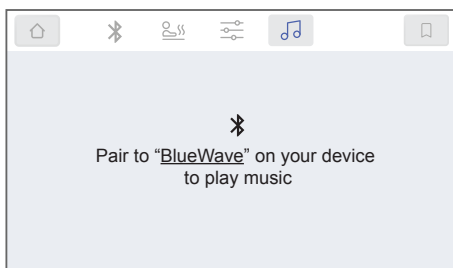


No device connected



Device connected

Note: There is no power button for the Stereo. It will detect either a Bluetooth or Auxiliary device and activate.



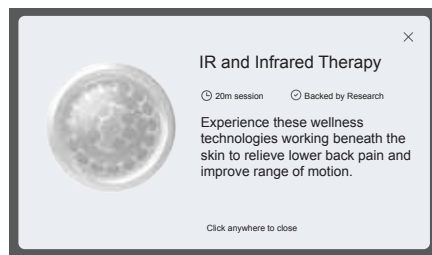
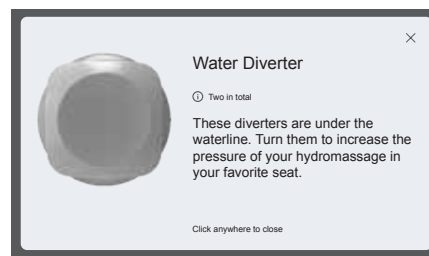
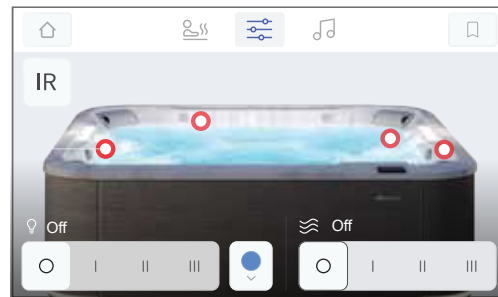
Connecting an Auxiliary Device

1. Remove the front panel.
2. Locate the BLUEWAVE unit in the equipment bay.
3. Locate the cable labeled "AUX" that is connected to the unit.
4. Use a 3.5 mm cable (not included) to connect your auxiliary device.
5. Run the cable safely, through the front, and reinstall the panel.

Note: Use caution when handling the auxiliary device, the placement of the device, and that the cable is not in the way.

Information Buttons

- Press each circle to display its information.

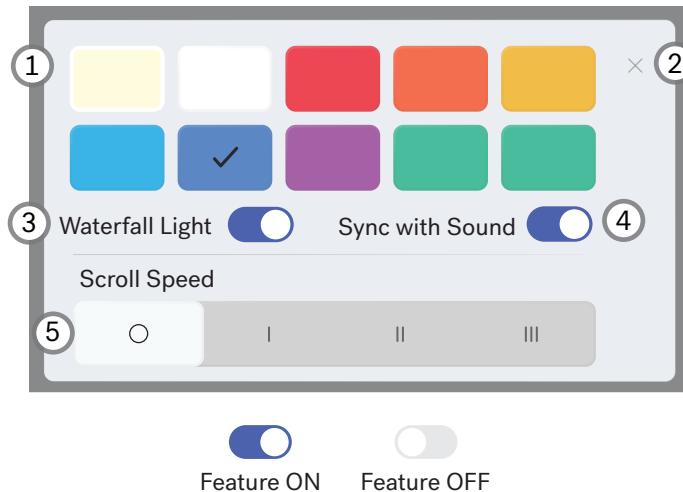


Light Intensity Control

- Press I for Low intensity.
- Press II for Ambient intensity.
- Press III for Bright intensity.



Lighting Options Menu



Photosensitivity Warning:

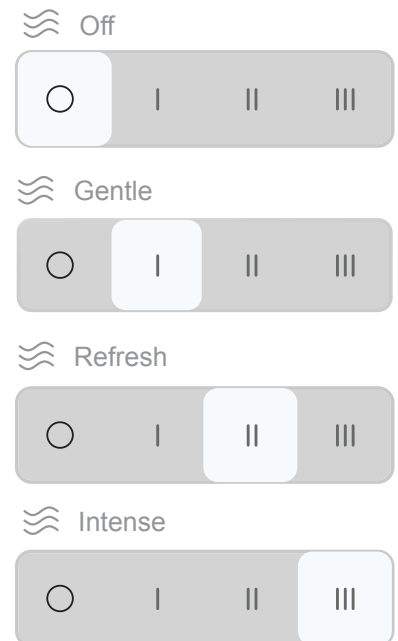
This product may emit light that could trigger seizures in individuals with photosensitive epilepsy or other light sensitivities. Use caution when operating this product. If you experience dizziness, altered vision, eye or muscle twitching, loss of awareness, or convulsions, discontinue use immediately and consult a physician.

1. Color selection buttons. Press a color to select.
2. Close menu button.
3. Waterfall light on or off control. Press to turn on () or off ().
4. Sync with sound on or off control. Press to turn on () or off ().
5. Scroll (blending) speed control. Press I for low blending mode. Press II for medium blending mode. Press III for high blending mode.

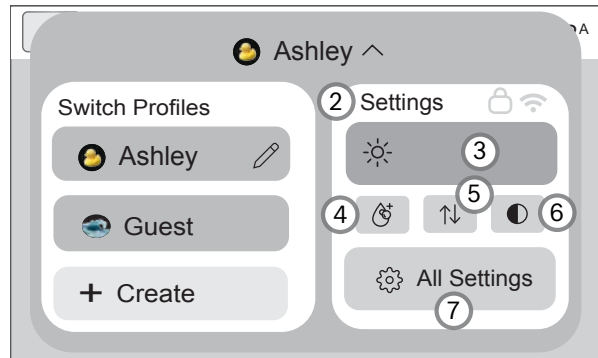
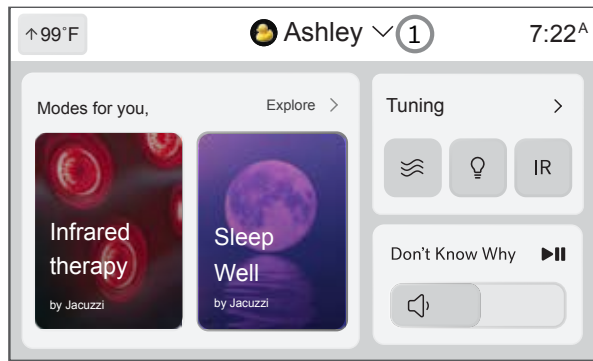
Hydromassage Control

Jets Pumps work in a combination of settings across all pumps. There are no individual controls for Pump 1, Pump 2 or Pump 3.

- Press I for Gentle setting.
 - 2-Pump System: Pump 1 on low; Pump 2 on low.
 - 3-Pump System: Pump 1 on low; Pump 2 on low, Pump 3 is off.
- Press II for Refresh setting.
 - 2-Pump System: Pump 1 on low; Pump 2 on high.
 - 3-Pump System: Pump 1 on high; Pump 2 on high, Pump 3 is off.
- Press III for Intense setting.
 - 2-Pump System: Pump 1 on high; Pump 2 on high.
 - 3-Pump System: Pump 1 on high; Pump 2 on high, Pump 3 is high.



Settings



1. Profile: Press to drop-down the options to access the Settings Menus. Press a second time to close the menu and return to the Home Menu.
2. Settings Widget: Provides access to various spa functions and menus. When locked a small lock will be displayed.
3. Control Panel Intensity: Slide from left to right to adjust the brightness level for the control panel.
4. Boost Cycle button: Press to activate the True Water® boost cycle for 1 hour.
5. Invert button: Press to invert the control panel display. Press a second time to invert back again.
6. Display Mode: Press to switch the Control Panel display mode from dark to light.
7. All Settings: Press to enter the Settings Menus.

All Settings

1. Home (Back) button
2. General Menu
3. Spa Care Menu
4. Security Menu
5. Troubleshoot Menu

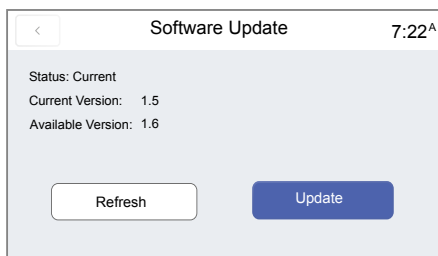
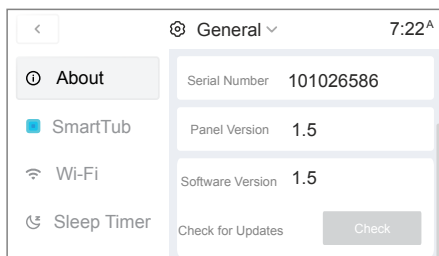
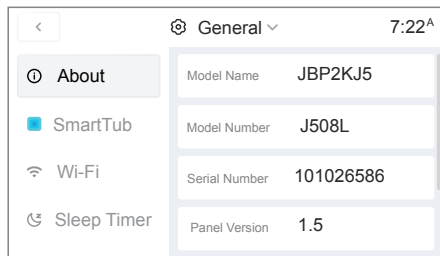
General Menus

The menus provide general information and simple programming for the hot tub. These menus consist of the following:

- About: Provides information about your spa.
- SmartTub: Provides a QR code to download the SmartTub® app.
- Wi-Fi: Allows connections to Wi-Fi networks.
- Sleep Timer: Allows you to program the Control Panel timeout.
- Date & Time: Allows you to automatically or manually set the date and time.
- Language: Allows you to choose a language.
- Temperature: Allows you program the temperature reading.
- Exterior lights: Allows operation for the exterior lights.

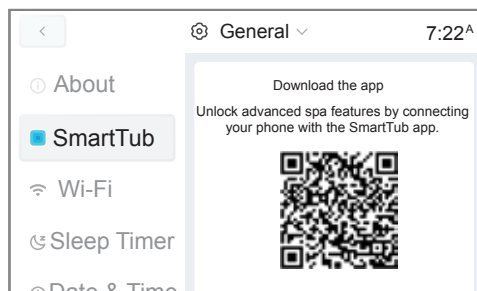
About Menu

- Scroll up and down to display general information such as:
 - Model Name
 - Model Number
 - Serial Number
 - Panel Version
 - Software version
 - Check for (software) updates. Once you press Update, the system will download and install the software.



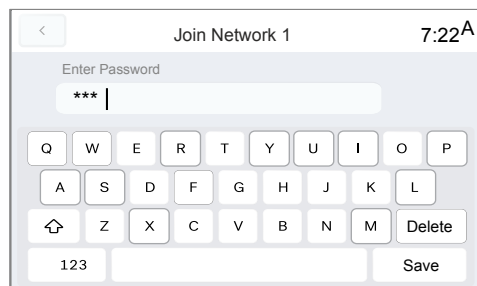
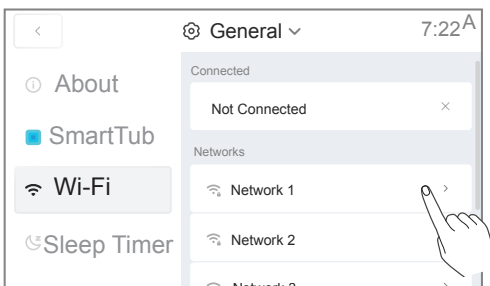
SmartTub®

- Click on the QR code to download and install the SmartTub® App.



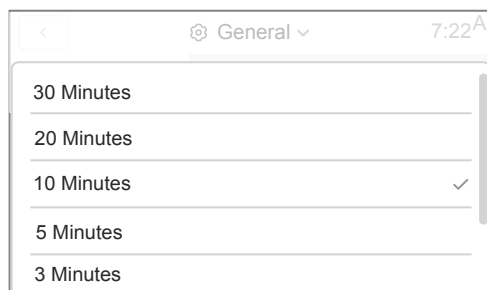
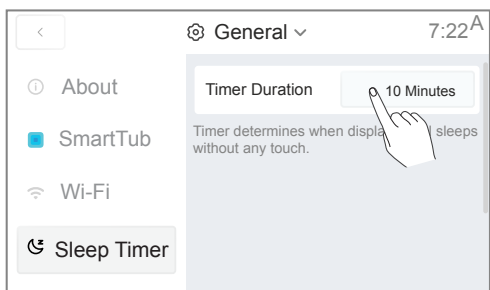
Wi-Fi

- Click on the QR code to download and install the SmartTub® App.
 - Tap the network you want to join.
 - Type in the password for that network.
 - Tap Save to exit and save the network information.



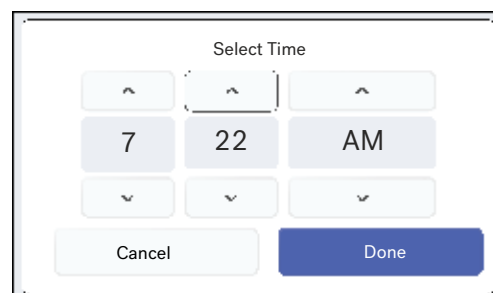
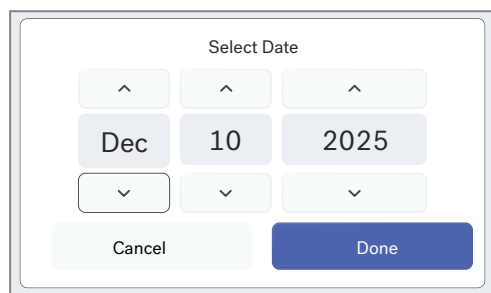
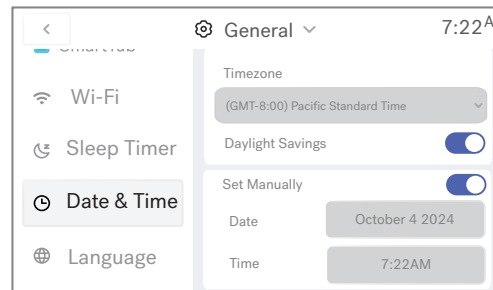
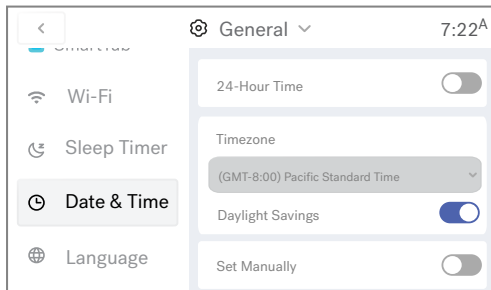
Sleep Timer

- You can set the timeout duration for the control panel to go to sleep.
 - Tap the minutes tab.
 - Select one of the five options. Once selected you will return to the Sleep Timer Menu.



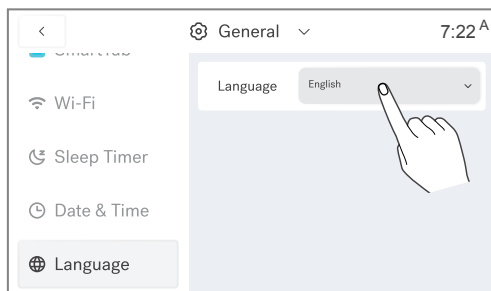
Date & Time

- Set the time either to a 12-hour or 24-hour configuration. Default setting is 12-hour.
- Set the Timezone.
- Activate or deactivate the Daylight Savings time adjustment. Default setting is off.
- Manually set the Date and Time.
 - Use the up and down arrows to scroll through the options to set the date and time. Press Done to save your changes.



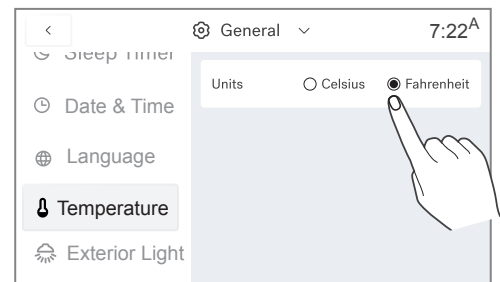
Language

- Tap the language tab.
- Select one of languages to display. Default language is English.



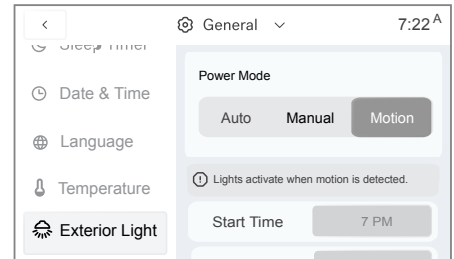
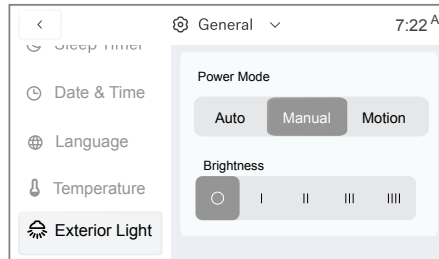
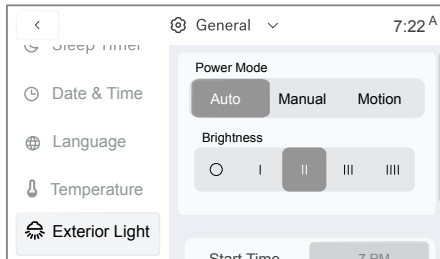
Temperature

- Tap either Celsius or Fahrenheit to select the temperature display. Default is Fahrenheit.



Exterior Light

- Tap one of the three Power Modes.
 - Auto: Activates the lights. The lights can be programmed to activate during a certain time period by setting a start and end time.
 - Manual: Activate the lights at any time.
 - Motion: The lights are on at low brightness. Lights brighten for 5 minutes when motion is detected by the sensor. The sensor has a 10-foot range. The lights can be programmed to activate during a certain time period by setting a start and end time.
- Tap to select one of the four Brightness levels. Feature is only available for the Auto and Manual Modes.



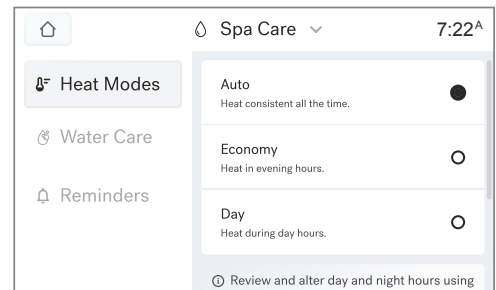
Spa Care

These menus consist of the following:

- Heat Modes: Allows you select one of heating options.
- Water Care: Allows you select the filtration options.
- Reminders: Allows you to program reminders for cleaning or changing components.

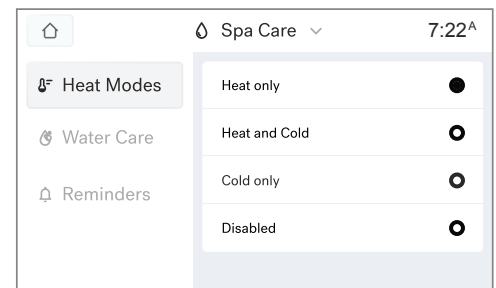
Heat Modes

- Auto: The hot tub maintains the water temperature to the programmed setting.
- Economy: The hot tub is only allowed to heat from 5:00 pm to 7:00 am.
- Day: The hot tub is allowed to heat from 7:00 am to 5:00 pm.



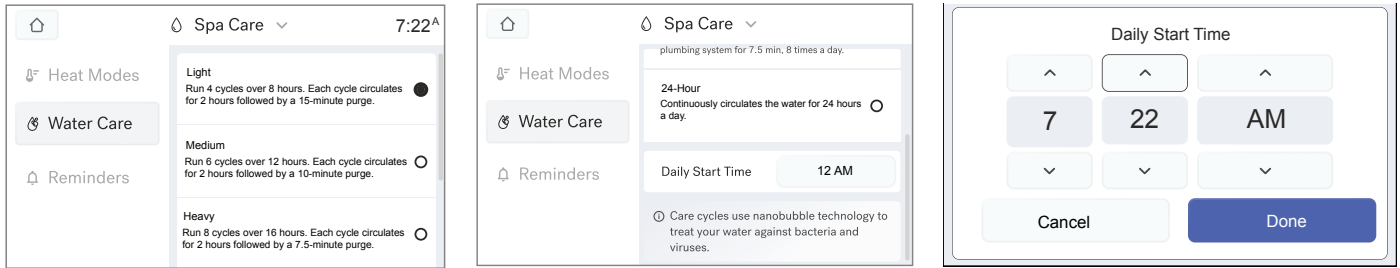
Heat Modes (when Heat Pump is installed)

- Heat only: The hot tub is allowed to only heat the water.
- Heat and Cold: The hot tub is allowed to heat or cool the water.
- Cold only: The hot tub is allowed to only cool the water.
- Disabled: The heat pump is disabled.



Water Care

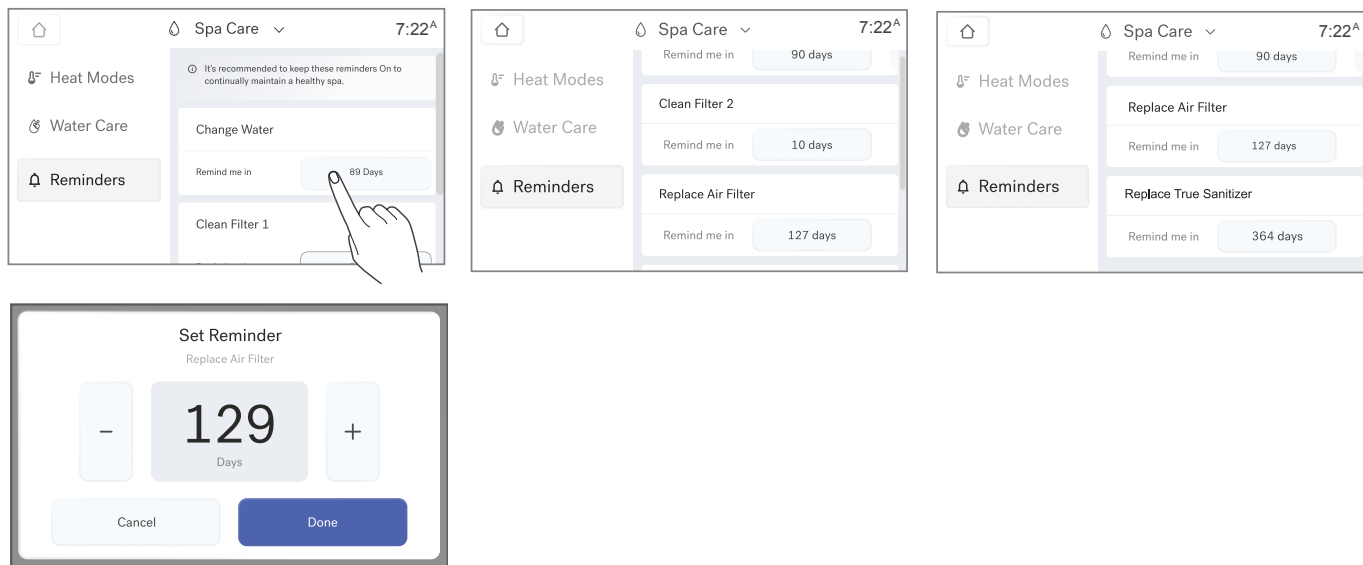
IMPORTANT NOTE: Any time the circulation pump runs outside of a program cycle, e.g. for heating, that run time will be deducted from the next filter cycle. For example, the factory filter cycle is set to 8 hours total and starts every 6 hours. If the circulation pump comes on for 1 hour to heat the water, the next filter cycle will only be for 1 hour not 2 hours.



- Light Mode (default cycle):
 - Cycle starts at 12:00 am but can be programmed to start at a different time.
 - 8 hours of filtration per day (2 hours every 6 hours). The duration cannot be altered.
 - The circulation pump and True Water® system are active.
 - Four 15-minute cycles, at the end of every filtration cycle, purge the circulation pump and air pump lines.
- Medium Mode:
 - Cycle starts at 12:00 am but can be programmed to start at a different time.
 - 12 hours of filtration per day (2 hours every 4 hours). The duration cannot be altered.
 - The circulation pump and True Water® system are active.
 - Six 10-minute cycles, at the end of every filtration cycle, purge the circulation pump and air pump lines.
- Heavy Mode:
 - Cycle starts at 12:00 am but can be programmed to start at a different time.
 - 16 hours of filtration per day (2 hours every 3 hours). The duration cannot be altered.
 - The circulation pump and True Water® system are active.
 - Eight 7.5-minute cycles, at the end of every filtration cycle, purge the circulation pump and air pump lines.
- 24 Hours:
 - The circulation pump and True Water® system are active.
 - System runs for 24-hours.
 - In extreme bitter cold weather, 32 °F (0 °C), we recommend you program the circulation pump to run 24 hours. Refer to the winterizing section.

Reminders

There are several reminders that can be set to countdown and appear when maintenance or a replacement is needed. We recommend having these reminders on.

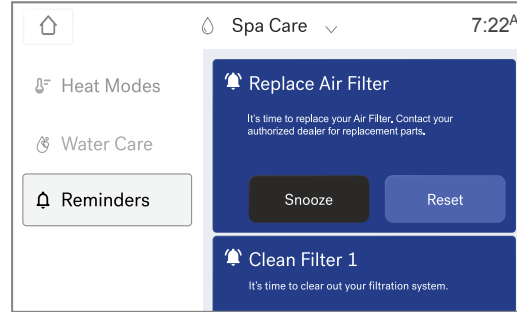
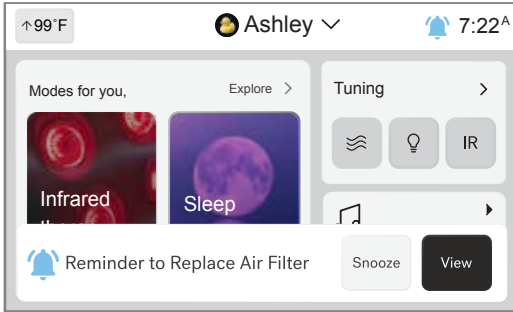


- **Change Water:**
 - Tap the days tab to enter the programming menu. Program the reminder from 10-180 days by pressing the - to +. Tap Done to save and exit the menu.
 - Once the timer expires you will need to change the water and reset the timer. A reminder message will appear.
 - Default setting is feature is on and programmed to 180 days.
- **Clean Filter 1:**
 - Tap the days tab to enter the programming menu. Program the reminder from 10-180 days by pressing the - to +. Tap Done to save and exit the menu.
 - Once the timer expires you will need to clean the ProClear filters and reset the timer. A reminder message will appear.
 - Default setting is feature is on and programmed to 180 days.
- **Clean Filter 2:**
 - Tap the days tab to enter the programming menu. Program the reminder from 10-90 days by pressing the - to +. Tap Done to save and exit the menu.
 - Once the timer expires you will need to clean the ProClarity filter and reset the timer. A reminder message will appear.
 - Default setting is feature is on and programmed to 90 days.
- **Replace Air Filter:**
 - Tap the days tab to enter the programming menu. Program the reminder from 10-180 days by pressing the - to +. Tap Done to save and exit the menu.
 - Once the timer expires you will need to replace the True Air filter and reset the timer. A reminder message will appear.
 - Default setting is feature is on and programmed to 180 days.
- **Replace True Sanitizer:**
 - Tap the days tab to enter the programming menu. Program the reminder from 10-730 days by pressing the - to +. Tap Done to save and exit the menu.
 - Once the timer expires you will need to replace the True Sanitizer (Ozone) and reset the timer. A reminder message will appear.
 - Default setting is feature is on and programmed to 730 days.

Reminder Message

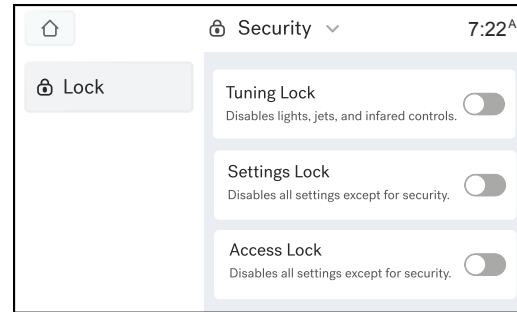
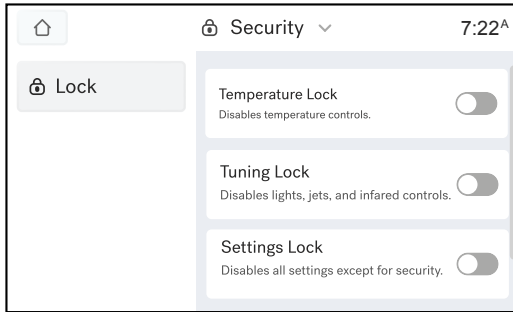
When a reminder time expires a message will appear.


- You must either clean or replace the component.
- After cleaning or replacing, you must reset the timer.
- If you snooze the reminder, it will reappear in 10 days.

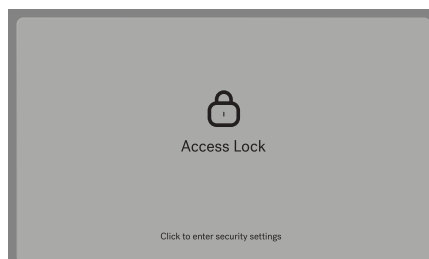
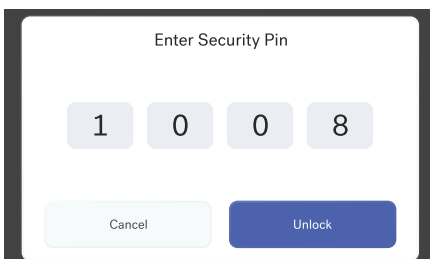
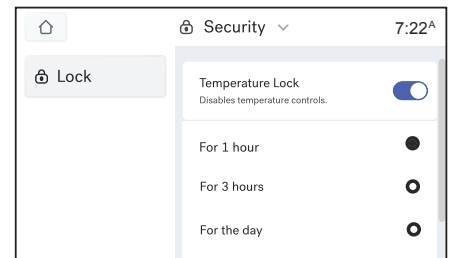
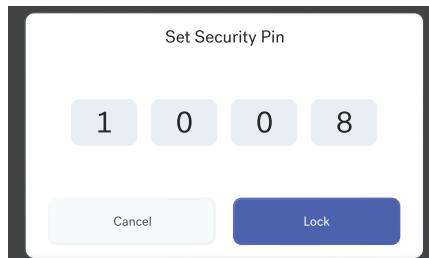
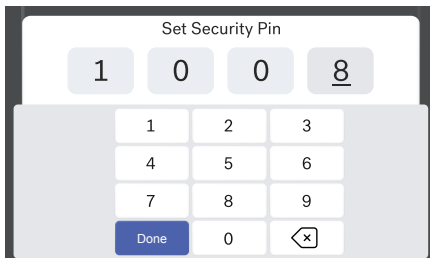


Security

- Temperature Lock: Disables the temperature settings to prevent any changes.
- Tuning Lock: Disables the lights, jets, and IR Therapy lights.
- Setting Lock: Disable all the settings except Security.
- Access lock: Disables everything except security. When this lock is activated, the panel will display an Access Lock message. You must unlock the panel to use it.

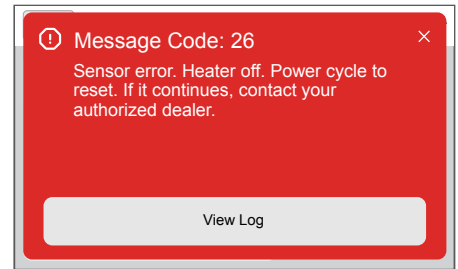
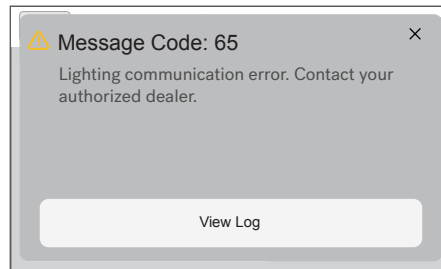
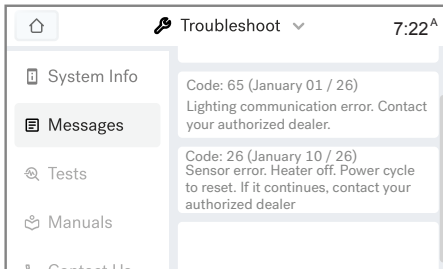


- Press to turn on ().
- Choose the lock feature you want to lock. You will be asked to enter a 4-digit code. Tap Lock
- After a menu will appear asking you to choose how long to leave the lock on for. Select one.
 - For 1 hour
 - For 3 hours
 - For the day
 - Until I turn it off
- To unlock the feature, tap its tab. Enter the 4-digit code, then tap unlock.
- A default code of 0772 can be entered if the security code is lost or forgotten.

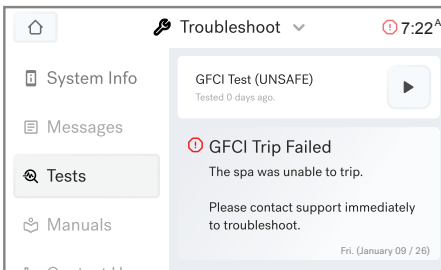
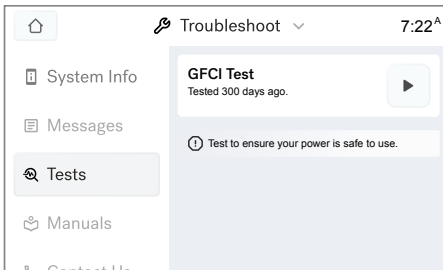


Troubleshooting

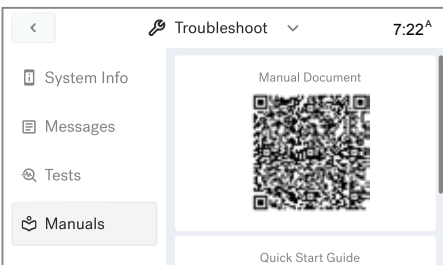
- System Information: Provides various information about the system. This menu is intended for Technicians.
- Messages: Displays a message log for any notifications.
 - These messages require your attention or call for action to be taken.



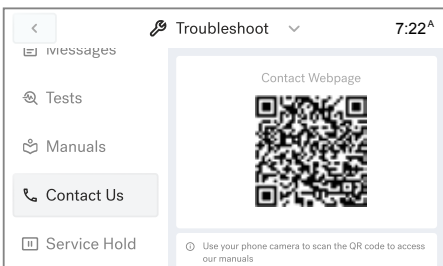
- Tests: Run a test to ensure that the GFCI is safe.
 - If the GFCI fails the test, it is considered unsafe. **DO NOT ENTER THE SPA!**



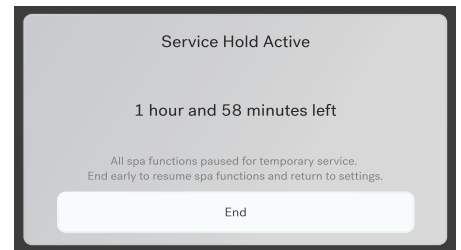
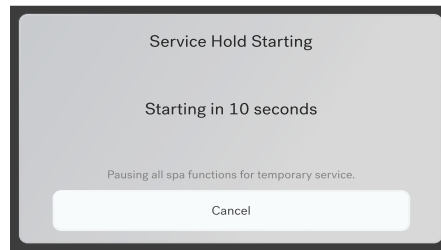
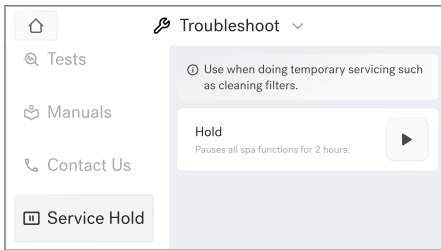
- Manuals: Scan the QR code to access the digital owner's manual.



- Contact Us: Scan the QR code access ways to reach us.



- Service Hold: Pauses all the spas' functions for 2 hours.
 - A service hold will appear on the control panel.
 - This hold can be used to clean the filters or perform small maintenance.
 - To remove the hold prior to the 2 hours, press the end tab.



Index

B

bromine **3, 4, 21, 22, 23, 38**

C

calcium **3, 21**

chlorine **3, 4, 19, 21, 22, 23, 38**

Control Panel **2, 3, 4, 6, 8, 20, 25, 32**

Cover Locks **5**

D

Draining the Spa **25**

I

Infrared Therapy **10**

L

Language **2, 11, 14**

M

metal **1, 3, 21, 25, 32**

Mode **2, 6, 12, 31**

N

nanobubbles **19, 38**

P

pH **3, 21, 23, 38**

phosphate **3, 21**

pillow **1, 8, 20, 25, 26**

Priming Mode **2, 31**

Profile **2, 3, 4, 6, 11**

S

Serial Number **4**

Setting your Temperature **9**

SmartTub **3, 4, 11**

SmartTub® **3, 4, 12, 20, 32, 39**

Sound and Soundscape **10**

Spa Cover **24**

T

Temperature **9, 11, 14, 17, 30**

Time Display **2**

Time Zone **2**

total alkalinity **3**

True Water **6, 19, 38**

True Water® **11, 15, 16, 19, 20, 21, 22, 32, 38**

Tuning your Hydrotherapy Experience **10**

A modern outdoor hot tub is the central focus, situated on a light-colored concrete patio. The hot tub is illuminated from below, and its water is bubbling. In the background, there is a modern building with large glass windows and a stone wall. A white sectional sofa is placed on the patio, and the ocean is visible in the distance under a sunset sky. The Jacuzzi logo is in the top right corner.

Jacuzzi®

Contact us:

Jacuzzi®

14525 Monte Vista Ave., Chino, CA 91710

Phone: 866-234-7727